

**Planiranje**

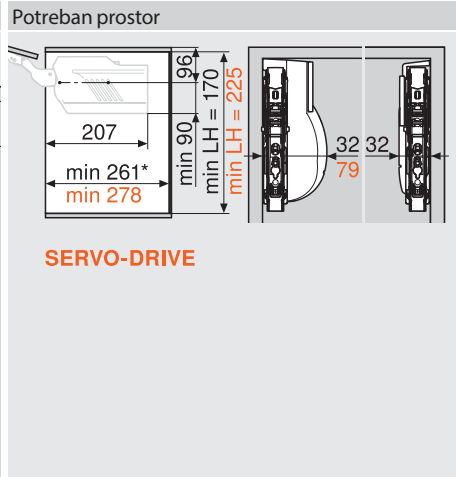
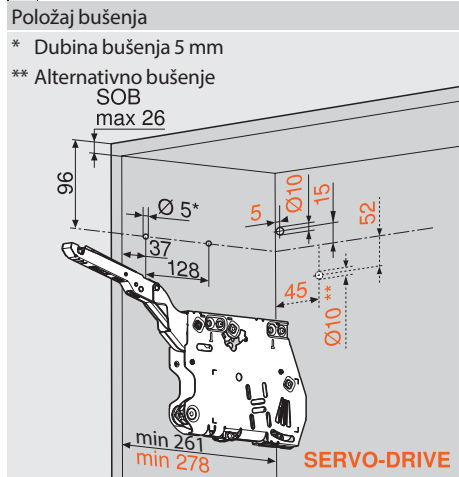

SOB Debljina gornje stranice korpusa  
 3 x vijci za šperploču Ø 4 x 35 mm  
 Rupa za SERVO-DRIVE kabel razdjelnika samo s lijeve strane

LH Svijetla visina korpusa  
 \* Min. 261 mm s vidljivim elementom za vješanje ormara

**Obrada fronti – drvene fronte i široki aluminijски okviri**

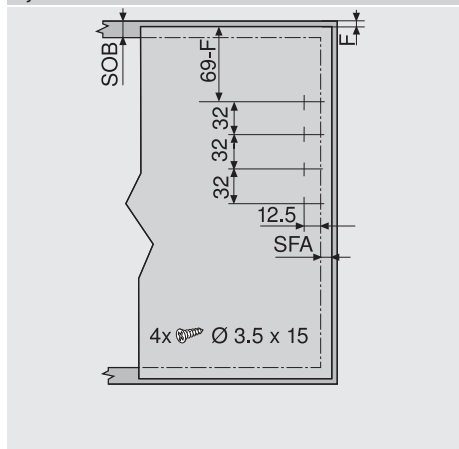

Za drvene fronte upotrebljavajte 4 vijka za ivericu (609.1x00). Za široke aluminijске okvire upotrebljavajte 4 vijka za lim s upuštenom glavom (660.0950)

**Obrada fronti – uski aluminijски okviri**

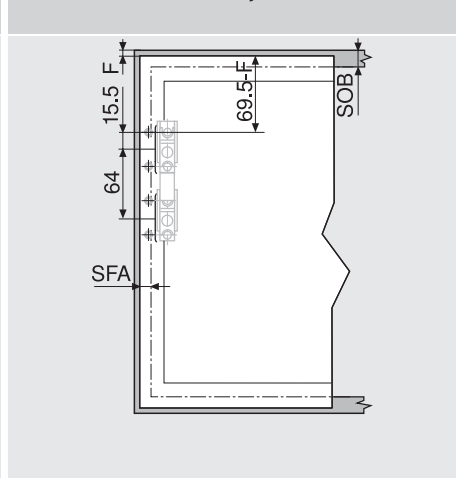

SOB Debljina gornje stranice korpusa  
 F Fuga  
 SFA Bočno otvaranje fronte

**Planiranje – uski aluminijски okviri**

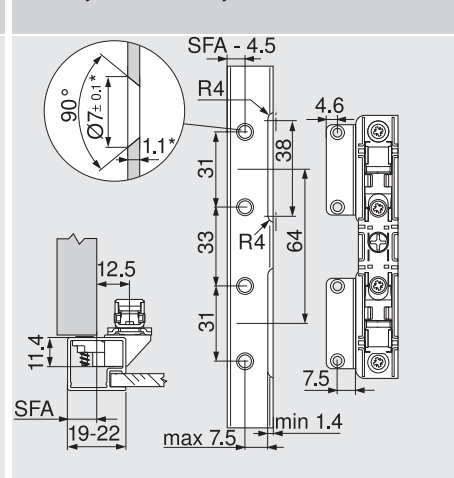

\* U slučaju promjene debljine materijala prilagodite dimenzije obrade  
 Kod okvira širine 19 mm moguće je bočno otvaranje fronte SFA od 11 - 18 mm

**Mjesto potrebno za ukrasni vijenac/bočnicu**

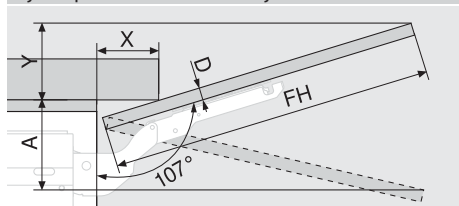

D (mm)	16	19	22	26	28
X (mm)	70	59	49	35	26
Graničnik kuta otvaranja	Potreban prostor (mm)				
Bez	Y = FH x 0.29 - 15 + D				
100°	Y = FH x 0.17 - 15 + D				
75°	A = FH x 0.26 + 15 - D				

**Najmanji bočni razmak**

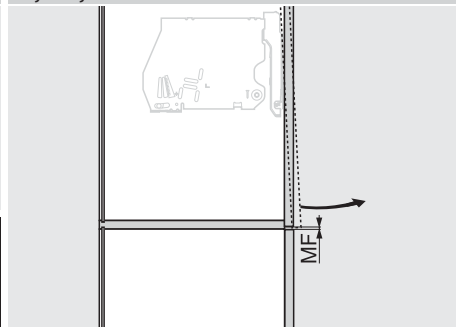

MF Najmanji bočni razmak 2 mm