

Mjesto potrebno
za ukrasni vijenac i bočnicu

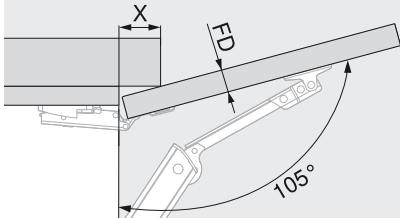

FD (mm)	16	19	22	24
X (mm)	45	34	23	15
FD	debljina fronte			

Najmanji bočni razmak

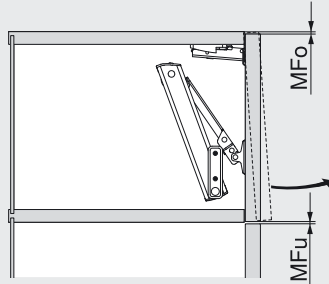

MFu najmanji bočni razmak dolje (1.5 mm)
MFo najmanji bočni razmak gore, ovisno o primijenjenoj spojnici – pogledajte katalog tvrtke Blum

CLIP top BLUMOTION 110°/
CLIP top 110°

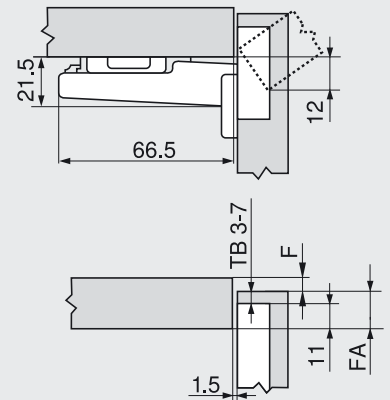

F razmak
OF otvaranje fronte
TB razmak bušenja čašice

Najmanji bočni razmak (F) za fronte s polumjerom fronte (R = 1 mm) pri tvorničkim postavkama za CLIP top BLUMOTION pod kutom od 110°/ CLIP top pod kutom od 110°

	Razmak bušenja čašice TB	Debljina fronte FD											Preporučujemo vam probno pričvršćivanje									
		16	18	19	20	21	22	23	24	25	26	28		30								
	3	0.5	0.8	1.0	1.2	1.5	1.8	2.2	2.7	3.5	4.3											
	4	0.5	0.8	1.0	1.2	1.4	1.7	2.0	2.5	3.1	3.8											
	5	0.5	0.8	0.9	1.2	1.4	1.7	2.0	2.4	2.9	3.4											
	6	0.5	0.8	0.9	1.2	1.3	1.6	1.9	2.3	2.7	3.2											
	7	0.5	0.8	0.9	1.1	1.3	1.6	1.9	2.2	2.6	3.0											
		Dodatno kod + 2 mm bočno podešavanje																				
		+0.2	+0.4	+0.4	+0.5	+0.5	+0.5	+0.5	+0.5	+0.5	+0.5	+0.5										

CLIP top BLUMOTION 110°/CLIP top 110°

Razmak bušenja čašice TB

	Otvaranje fronte FA																	
	5	6	7	8	9	10	11	12	13	14	15	16	17	18				
0												3	4	5	6	7		
3								3	4	5	6	7						
6				3	4	5	6	7										
9	3	4	5	6	7													

Podložak