

Modell: FMM 350 QSL (50/60Hz, 220/230V)
Best.-Nr.: 72295200230



Pos.	Best.-Nr.	Benennung	Stück	Status
10	31901173000	Motorgehäuse	1	*
30	32805311000	Schaltschieber	1	*
70	30712087015	Bürstenhalter	2	*
80	30711157000	Kohlebürste	2	*
110	30762453990	Elektronik	1	*
130	32431045000	Kabelklemmstück	1	*
155	31415110000	Druckstück	4	*
160	43074010000	Schraube	7	*
170	43074002000	Schraube 35X20	2	*
180	30707343017	Kabel mit Stecker	1	*
190	31413233000	Kabeltülle	1	*
230	31603053010	Lagerbuchse	1	*
250	53278005230	Anker	1	*
260	41701001032	Rillenkugellager	1	*
270	41701007038	Rillenkugellager	1	*
285	32172014010	Magnet	1	*
290	40612167000	Dichtring	1	*
300	41701000020	Rillenkugellager	1	*
310	42616046003	Sicherungsring	1	*
350	52278046230	Statoreinheit	1	*
405	31508287030	Maschinenkopf	1	*
430	34300000012	Hebel	1	*
480	33218150000	Exzenterring	1	*
490	40242064000	Zylinderstift	1	*

Modell: FMM 350 QSL (50/60Hz, 220/230V)
Best.-Nr.: 72295200230



Pos.	Best.-Nr.	Benennung	Stück	Status
495	30507220000	Buchse	2	*
510	30907067000	Haltefeder	1	*
520	43064023045	Linsenschraube	1	*
530	43074009000	Schraube	4	*
5000	33901131920	Kunststoff-Werkzeugkoffer	1	*
5010	33218136000	Saughaube	1	*
5020	30601106007	Filzring	2	*
5030	30605112000	Adapter	1	*
5040	33218137010	Absaugeinheit	1	*
5200	32119122000	Griff	1	*
5210	30232050000	Drahtbügel	2	*
5300	33904488000	EPP-Einsatz	1	*
5450	63806136220	Schleifplatten-Set, gelocht	1	*
5500	92602091000	Absaug-Set	1	*
6000	32160003014	Schmiermittel-Tube 0,085 kg	1	*
9000	34101242060	Betriebsanleitung	1	*
9020	34130054061	Sicherheitshinweis	1	*

Modell:
Best.-Nr.:

FMM 350 QSL (50/60Hz, 220/230V)
72295200230

7 229 52 - FMM350 QSL

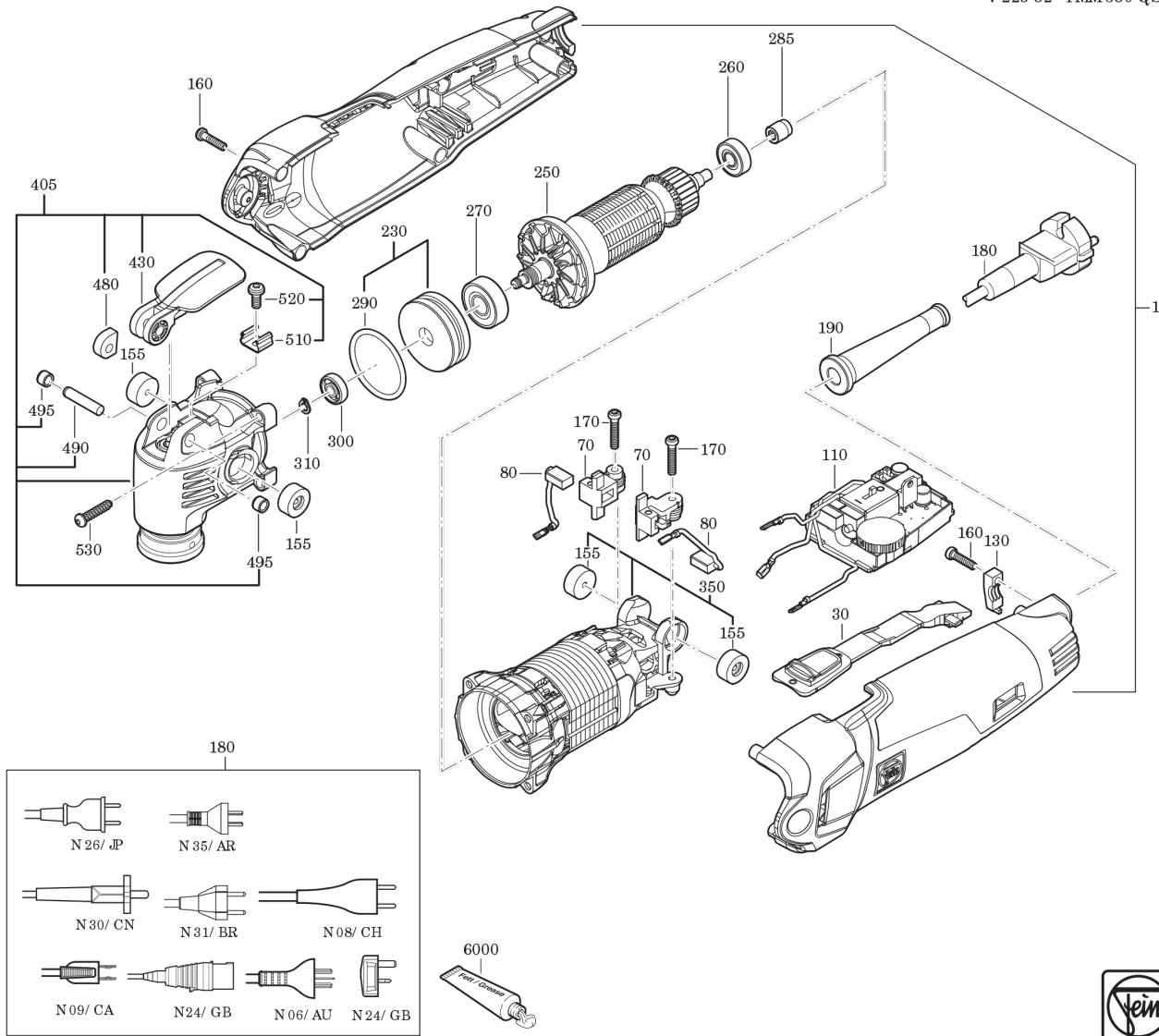

Modell:
Best.-Nr.:

FMM 350 QSL (50/60Hz, 220/230V)
72295200230

7 229 52 - FMM 350 QSL

