

Modell: SCT 5-40 X (50/60Hz, 220/230V)
Best.-Nr.: 72131300230



Pos.	Best.-Nr.	Benennung	Stück	Status
10	31901138011	Motorgehäuse	1	*
20	30701228002	Schalter	1	*
21	43013052033	Zylinderschraube	2	*
30	30722183018	Kondensator	1	*
40	30701249004	Umschalter	1	*
60	30712089039	Bürstenhalter	2	*
65	30711165000	Kohlebürste 100-240V,50/60Hz	2	*
80	43070018009	Schraube	2	*
90	51274014230	Stator	1	*
100	43070014000	Schraube	2	*
110	31428149008	Luftleitring	1	*
120	32431046000	Kabelklemmstück	1	*
130	43070006008	Schraube	1	*
160	30719544014	Verbindungskabel	1	*
170	30719545018	Verbindungskabel	1	*
180	30719630014	Verbindungskabel	1	*
190	31201136010	Handgriffhalbschale	1	*
200	31201137000	Handgriffhalbschale	1	*
205	31201136030	Handgriff Repair-Set	1	*
210	32805191002	Schaltknopf	1	*
220	43066009038	Senkschraube	1	*
240	43046003009	Blechschraube	2	*
250	43070007002	Schraube	1	*
270	30707343017	Kabel mit Stecker	1	*

Modell: SCT 5-40 X (50/60Hz, 220/230V)
Best.-Nr.: 72131300230



Pos.	Best.-Nr.	Benennung	Stück	Status
280	31413233000	Kabeltülle	1	*
300	30610041000	Dichtung	1	*
301	53274019230	Anker z=5 220-230V,50/60Hz	1	*
310	32612063005	Dichtring	1	*
340	41701001172	Rillenkugellager	2	*
355	31506367014	Zwischenlager	1	*
360	31508251002	Getriebegehäuse	1	*
370	41719026007	Scheibe	1	*
380	41715029009	Nadelkäfig	1	*
390	32408395000	Scheibe	1	*
400	33657161007	Zahnrad	1	*
410	32624094032	Scheibe	2	*
420	30901139007	Spiralfeder	1	*
440	30104133006	Werkzeugträger	1	*
445	30102101013	Kupplungsring Z=13	1	*
460	41708014001	Kugel	1	*
470	31603045005	Buchse	1	*
480	40612093004	Dichtring	1	*
490	30503151006	Hülse	1	*
500	30901362001	Spiralfeder	1	*
510	32601274004	Ring	1	*
520	42615147001	Sicherungsring	1	*
705	30505069011	Überwurfhülse	1	*
710	41708019004	Kugel	2	*

Modell: SCT 5-40 X (50/60Hz, 220/230V)
Best.-Nr.: 72131300230



Pos.	Best.-Nr.	Benennung	Stück	Status
720	40612071009	Dichtring	1	*
730	32127068000	Hülse	1	*
960	43072010009	Schraube	3	*
1010	63901011059	Halter	1	*
1040	30232046008	Aufhängevorrichtung	1	*
5000	60510215003	Halter 1/4 in Außensechskant	1	*
5010	62712109034	Bits 1/4" Außensechskant	1	*
6000	32160003217	Schmiermittel-Tube 0,085 kg	1	*
9000	34101102060	Betriebsanleitung	1	*
9020	34130054061	Sicherheitshinweis	2	*

Modell:
Best.-Nr.:

SCT 5-40 X (50/60Hz, 220/230V)
72131300230

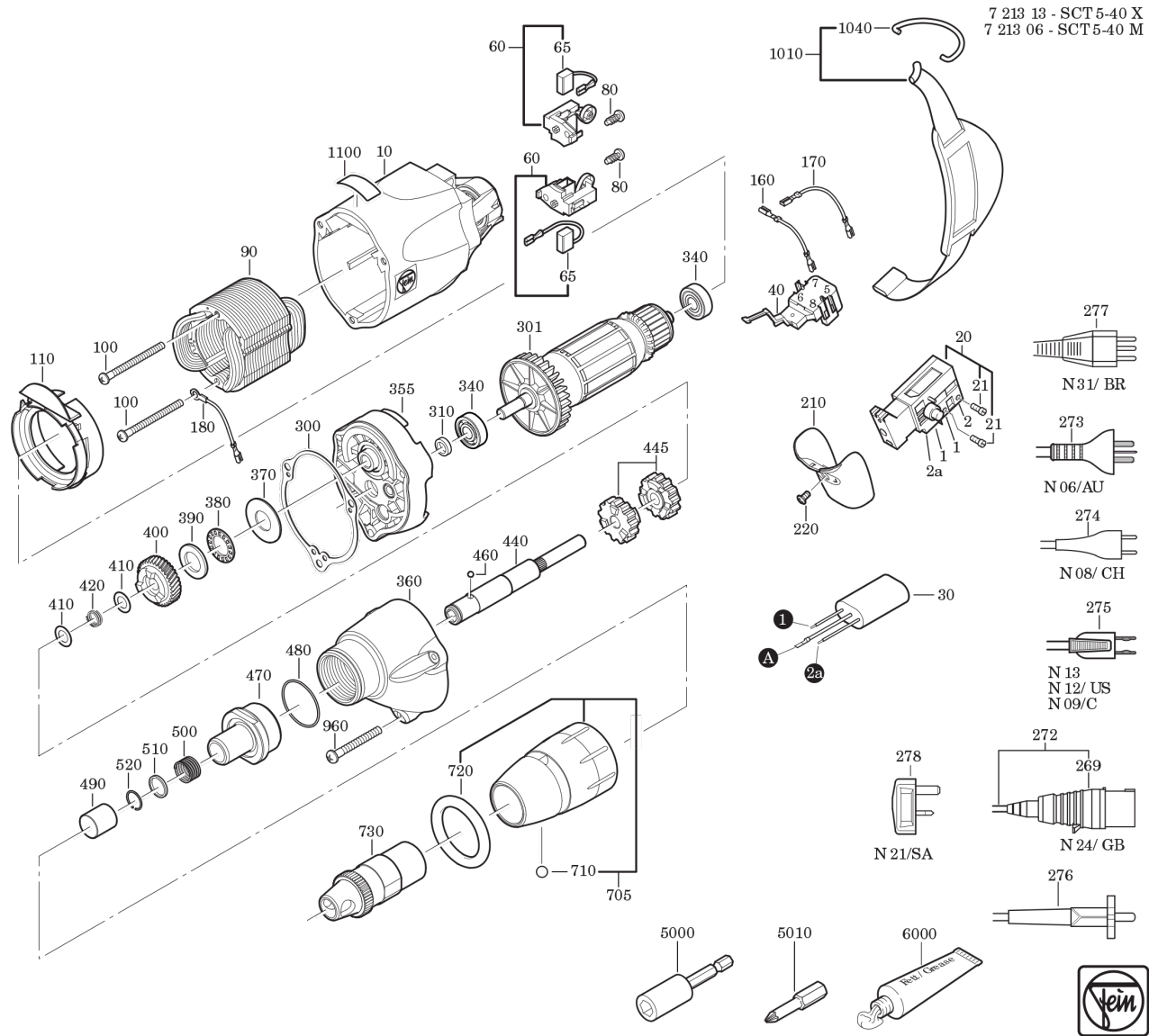

Modell:
Best.-Nr.:

SCT 5-40 X (50/60Hz, 220/230V)
72131300230

7 213 13 - SCT 5-40 X
7 213 06 - SCT 5-40 M

→ 06.2010

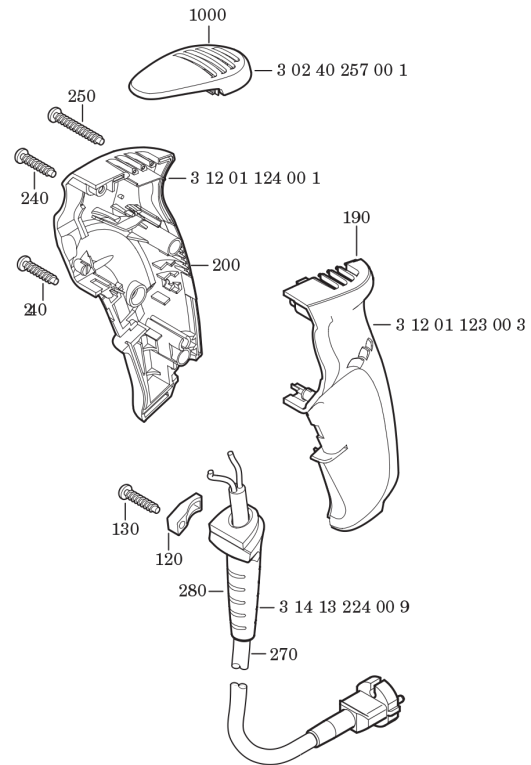

06.2010 →

