

**NOTE: Order parts by Catalog Number only.  
DO NOT order by Reference Number.**

Ref. No.	Catalog No.	Description
1	45663	Linecord 115V CE
	45668	Linecord 115V CSA
	45673	Linecord 220V CN
	45678	Linecord 230V CE
	45683	Linecord Swiss
2	45658	Strain Relief
3	45618	Capacitor (220V/230V/115V EU)
4	45613	Slide Switch
5	45608	FOR/REV Switch
6	45633	Right Handle
7	45778	Red Brush Lead
8	45783	Black Brush Lead
9	45598	Brush Cap (2)
10	45593	Brush Assembly 115V (2)
	45588	Brush Assembly 230V (2)
11	45583	Brush Holder (2)
12	45578	Motor housing
13	45758	Red Field Lead
14	45763	Blue Field Lead
15	45768	Brown Field Lead
16	45773	Black Field Lead
17	45573	Field Mounting Screw (2)
18	45563	Field 115V
	45568	Field 220V/230V
19	47108	Warning Decal
20	45623	ON/OFF Trigger
21	45603	Left Handle
22	45628	Screw (2)
23	45498	Screw (6)
24	45638	Screw (3)
25	45653	Screw (2)
26	45648	Cord Clamp
27	45558	Fan Shroud
28	45553	Bearing Sleeve
29	45548	Armature Bearing
30	45543	Dust Shroud
31	45528	Armature Pinion Bearing
32	48588	Armature Sleeve
33	45533	Armature Asm. 115V
	45538	Armature Asm. 230V
34	47798	Gasket
35	45223	Spring Ring
36	45518	Spacer Bearing
37	45513	Bearing Washer
38	48593	Lip Seal
39	34392	Fan Housing
40	45508	Washer (4)

## Wiring Diagrams

### 115V

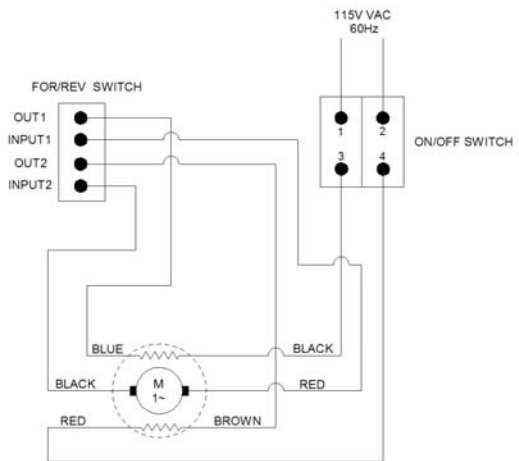

### 220/230V

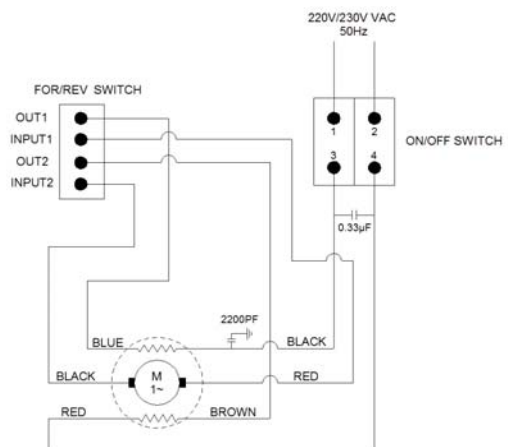

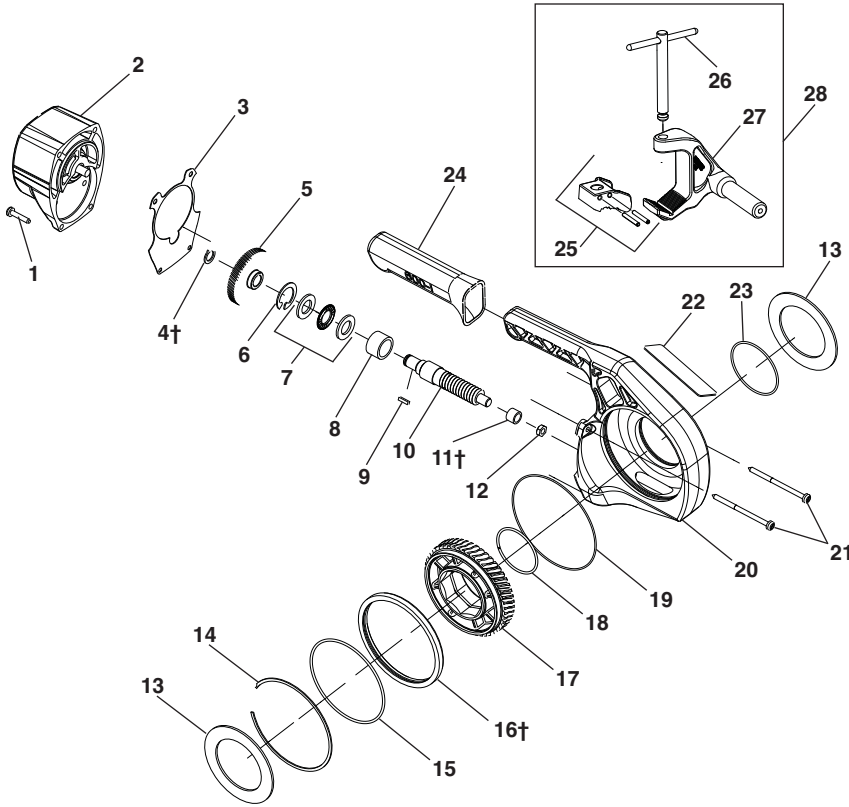

**NOTE: Order parts by Catalog Number only.  
DO NOT order by Reference Number.**

Ref. No.	Catalog No.	Description
1	34387	Screw (2) (5.8 x 25mm)
2	34392	Fan Housing
3	34512	Gasket
4†	34447	Retaining Ring
5	34452	Helical Gear
6	34457	Retaining Ring
7	34462	Thrust Bearing
8	34467	Needle Bearing
9	34472	Key
10	34477	Worm
11†	34482	Needle Bearing
12	77710	Hex Nut
13	34402	Cap (2)
14	34442	Spiral Ring
15	34407	O-Ring, 4" X 4 1/8" X 1/16" Buna N
16†	34432	Ring Bearing
17	34427	Worm Gear
18	38830	Spring Ring
19	34422	O-Ring, 4 1/2" X 4 5/8" X 1/16" Buna N
20	34417	Gear Housing
21	34412	Screw (2) (4.8 x 80mm)
22	47103	Icon Warning Decal
23	34437	O-Ring, 2 1/2" X 2 5/8" X 1/16" Buna N
24	47083	Hand Grip
25	47743	602 Bottom Jaw Assembly
26	47563	602 Screw Assembly
27	47558	Arm
28	45923	602 support Arm Assembly
	34522	Worm Gear Lubricant (2 oz.) Not Shown

## Service Notes

### Gear Head Assembly

#### Proper Oil Fill Procedure: Capacity 2 ozs.

- Step 1: Wipe Gear Cavity with oil and assemble Gear Head.  
 Step 2: Fill Worm Cavity  $\frac{1}{2}$  full of oil - install Worm.  
 Step 3: Pour remaining oil in Helical Gear Cavity - install Helical Gear.  
 Step 4: Install new Gasket and attach motor Assembly with Gear Head upright.

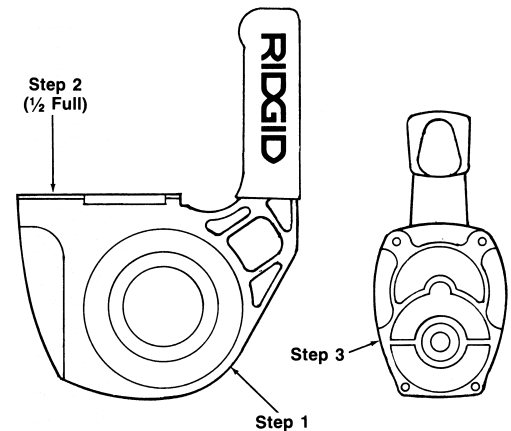

#### †Ref. No. 11

Hex Nut has been inserted behind Needle Bearing (Ref. No. 11) in the Gear Housing Assembly (Ref. No. 20). To replace Needle Bearing, thread 6 mm or  $\frac{1}{4}$  - 20 rod into nut and pull Bearing.

#### †Ref. No. 16

Chamfered edge of Ring Bearing must be installed (down) into Worm Gear.

#### †Ref. No. 4

Chamfered edge of Retaining Ring must be installed facing Gear.