

## ERSATZTEILE | STROMLAUFPLÄNE GP 250/500

Spare parts | Pièces de rechange | Onderdelen | Reservedele | Varaosat | Pezzi di ricambio  
Reservedelen | Peças | Reservdelar | Piezas de recambio | Запасные части

Circuit diagrams | Schéma de connexions | Stroomschema | Kredslobsdiagrammer  
Kytkentäkaavio | Aansluitschema | Schema elettrico | Koplingskjema | Esquema electrico  
Elschema | Esquema eléctrico | Принципиальные электрические схемы

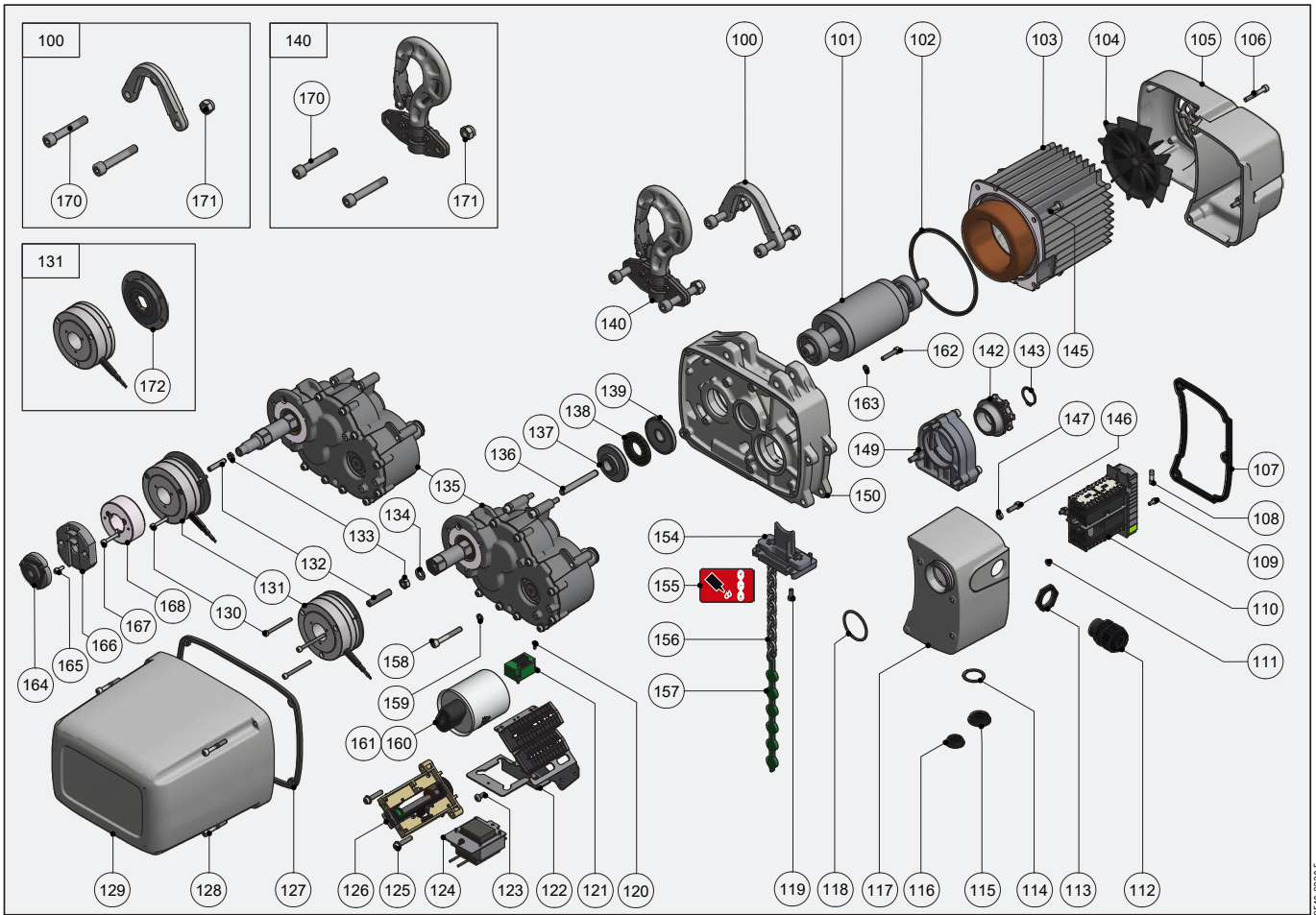



9510.9270.5

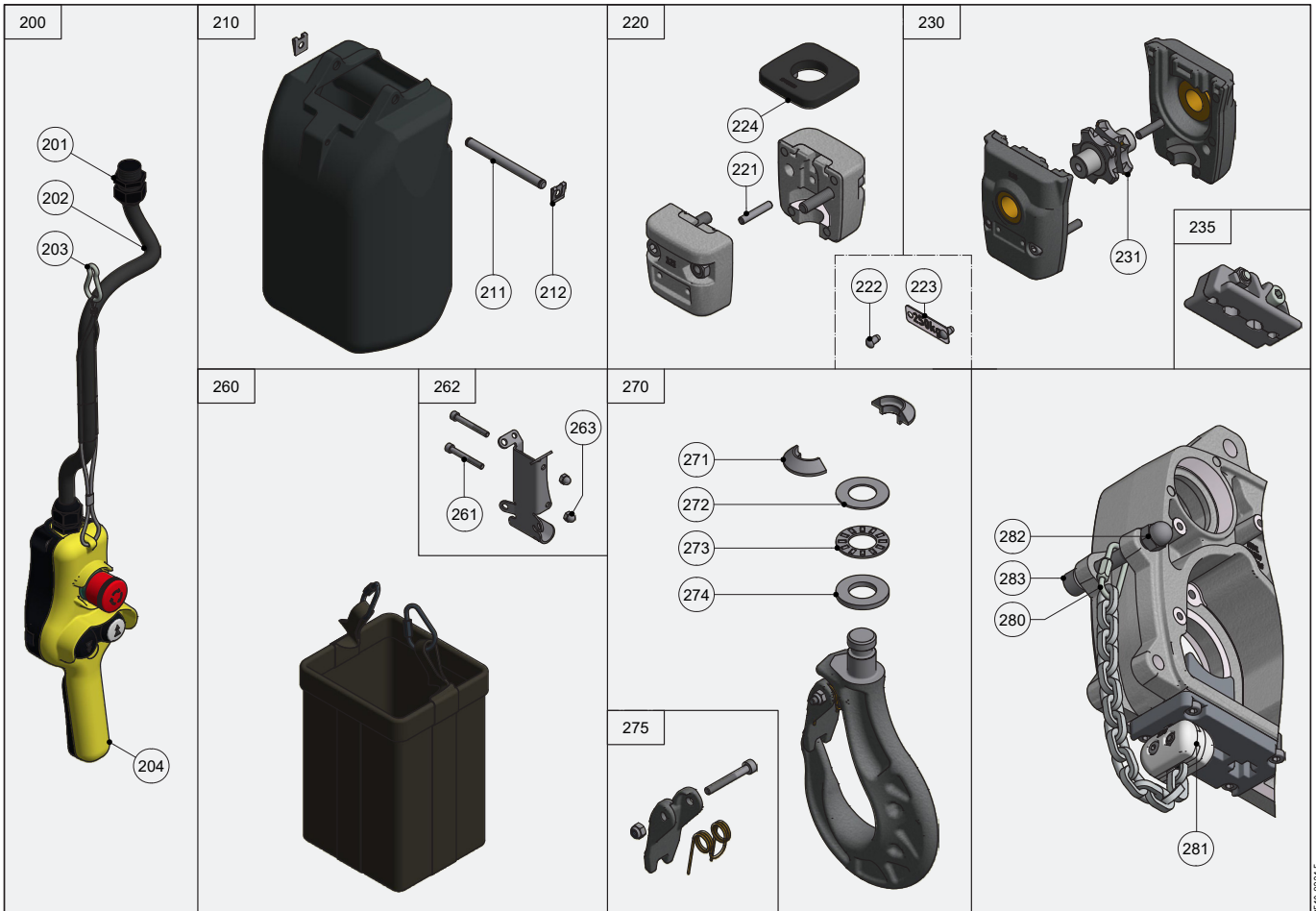

9510.9271.5



Schützensteuerung Contactor control Commande par contacteurs	1 Geschwindigkeit mit Not-Aus 1 speed with emergency stop 1 vitesse avec marche-arrêt	9510.9500.4 / 3 Ph
	2 Geschwindigkeiten mit Not-Aus 2 speeds with emergency stop 2 vitesses avec marche-arrêt	9510.9501.4 / 3 Ph
	1 Geschwindigkeit mit Not-Aus 1 speed with emergency stop 1 vitesse avec marche-arrêt	9510.9601.3 / 1 Ph

F	Steuersicherung	Control fuse	Fusible de commande
K	Schütz	Contacteur	Contacteur
L	Zuleitung	Power supply	Alimentation électrique
N	Nullleiter	Neutral	Neutre
NA	Not-Aus	Emergency stop	Marche-arrêt
PE	Erdung	Earth	Mise à la terre
S	Schalter	Switch	Interrupteur
T	Transformator	Transformer	Transformateur
U, V, W	Motor	Motor	Moteur
X	Klemmenleiste	Terminal strip	Bornier de raccordement
Y	Bremse	Brake	Frein

9510.9500.4 / 3 Ph

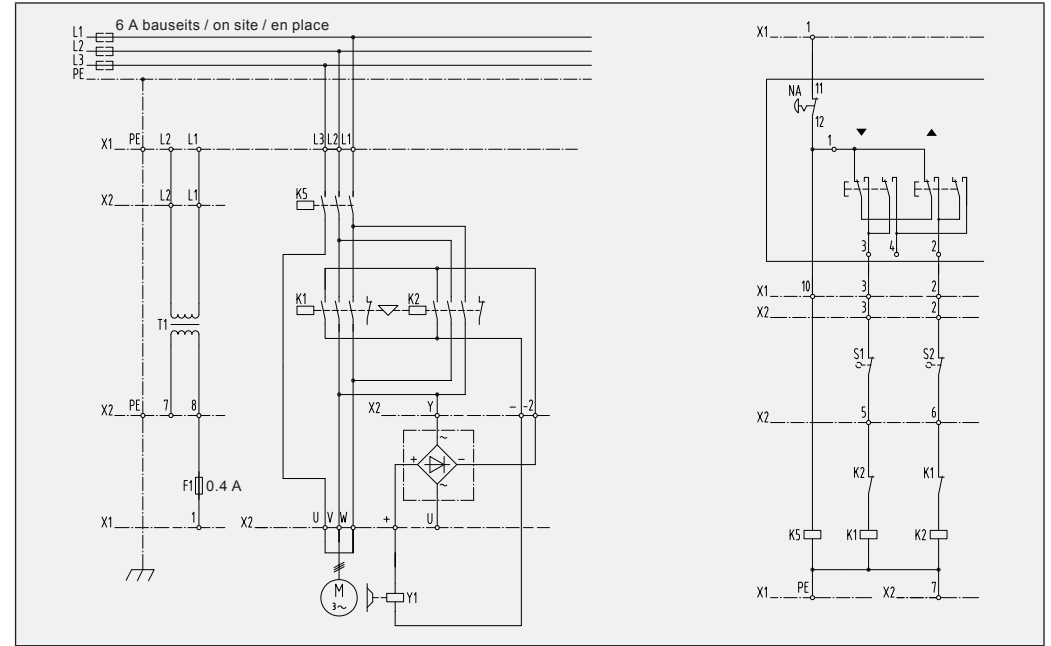

9510.9601.3 / 1 Ph

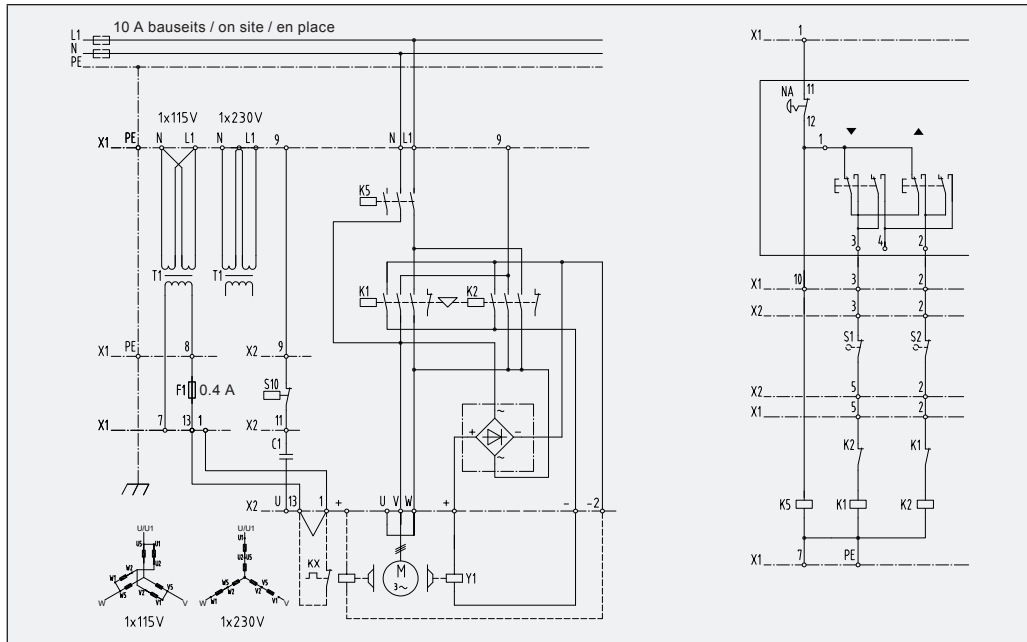

9510.9501.4 / 3 Ph

