

# VS ENVI® Water

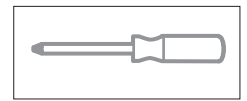

## Montage

- EN Assembly
- NL Montage
- FR Montage
- DA Montage
- NO Montering



## VS ENVI® Water

## Quooker Pro3 + CUBE

## VS ENVI® Space

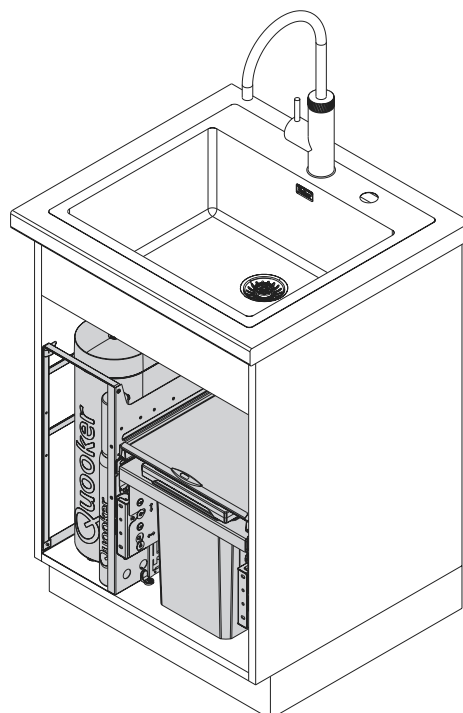
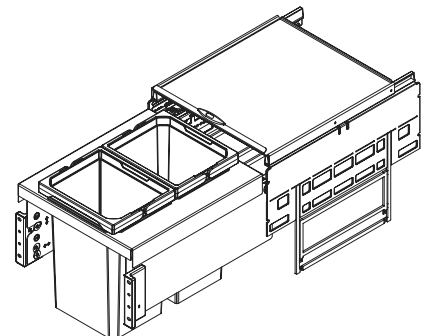
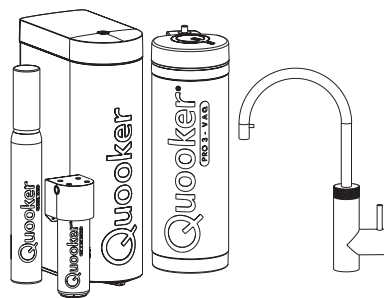
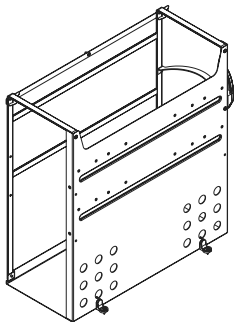

### Option

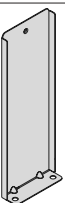

VS ENVI Water Filter

## Korpus Abmessungen

EN Cabinet dimensions

NL Afmetingen corpus

FR Dimensions du corps

DA Selve enhedens dimensioner

NO Hoveddelens dimensjoner

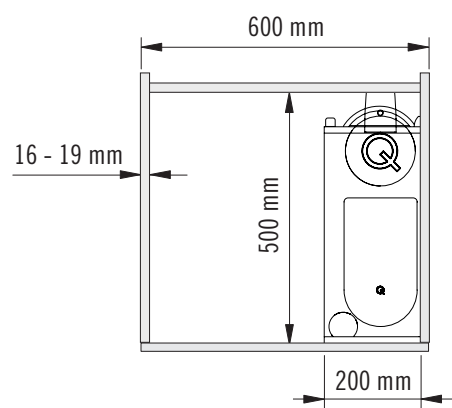
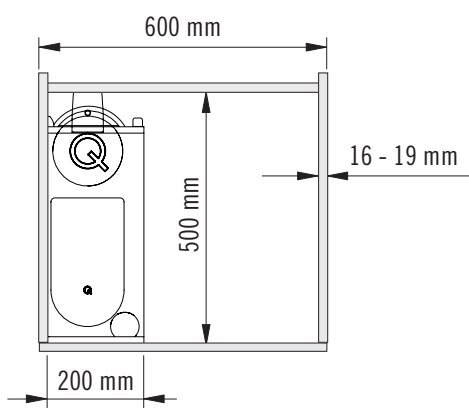
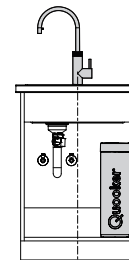
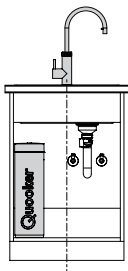
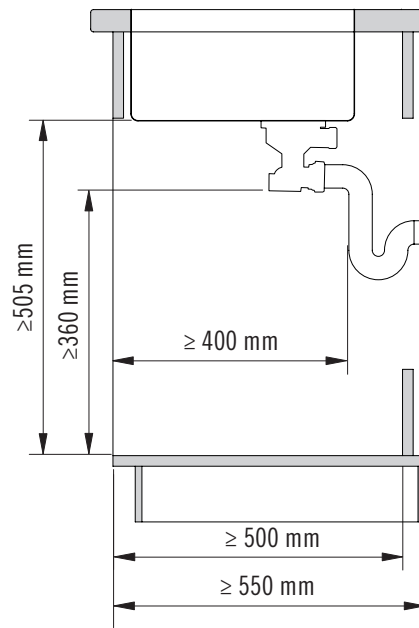



# VS ENVI® Water

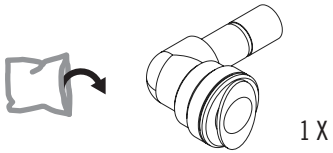
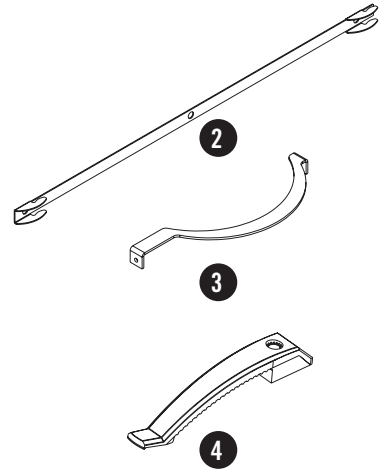
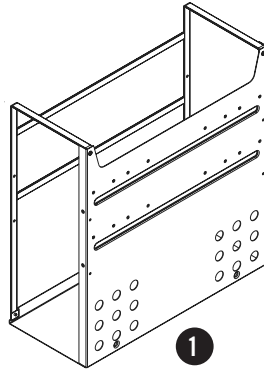

1 X

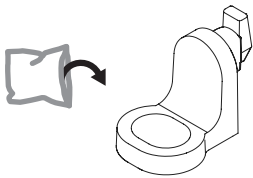

2 X

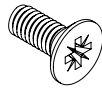

M4 x 10 mm  
(5 X)



M4 x 8 mm  
(1 X)

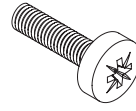

M5 x 20 mm  
(1 X)

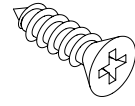

4 x 16 mm  
(2 X)

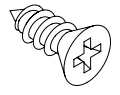

4 x 13 mm  
(3 X)



4 X

## VS ENVI® Water 4.2

1

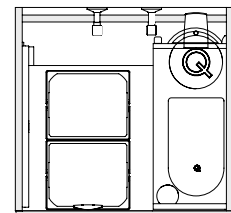
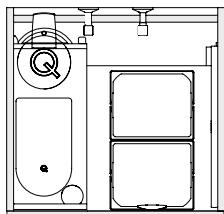
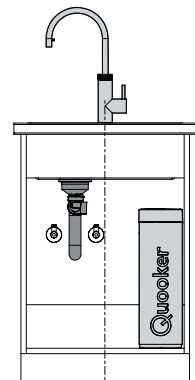
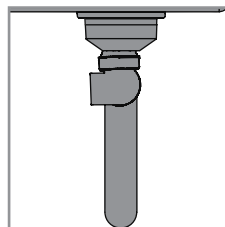
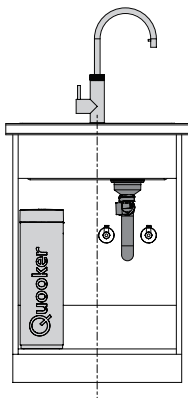

# 2

## Montage Kabelklemme

EN Assembly cable clamp

NL Montage kabelklem

FR Montage du serre-câble

DA Montage kabelklemme

NO Montering kabelklamme



PZ 2

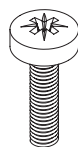
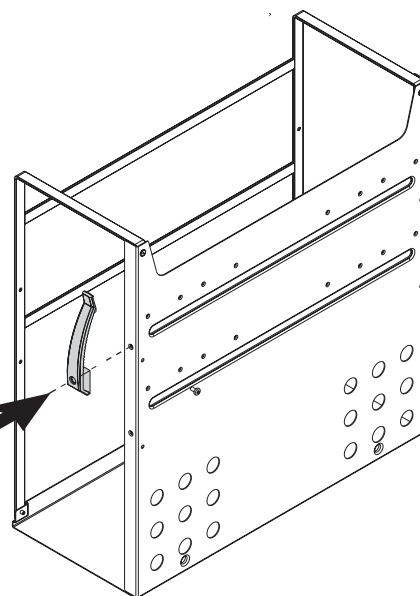
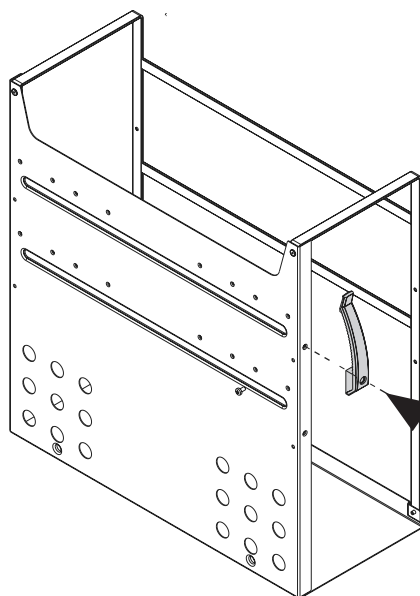
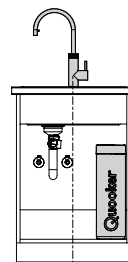
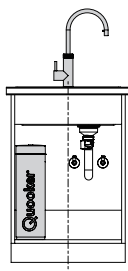
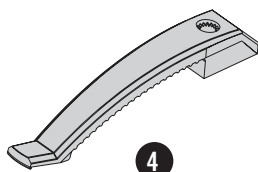

M5 x 20 mm  
(1 X)

# 3

## Montage Kippschutz

EN Assembly tilt protection

NL Montage kantelbeveiliging

FR Montage du dispositif anti-basculement

DA Montage anti-vippeanordning

NO Montering veltevern



PZ 2

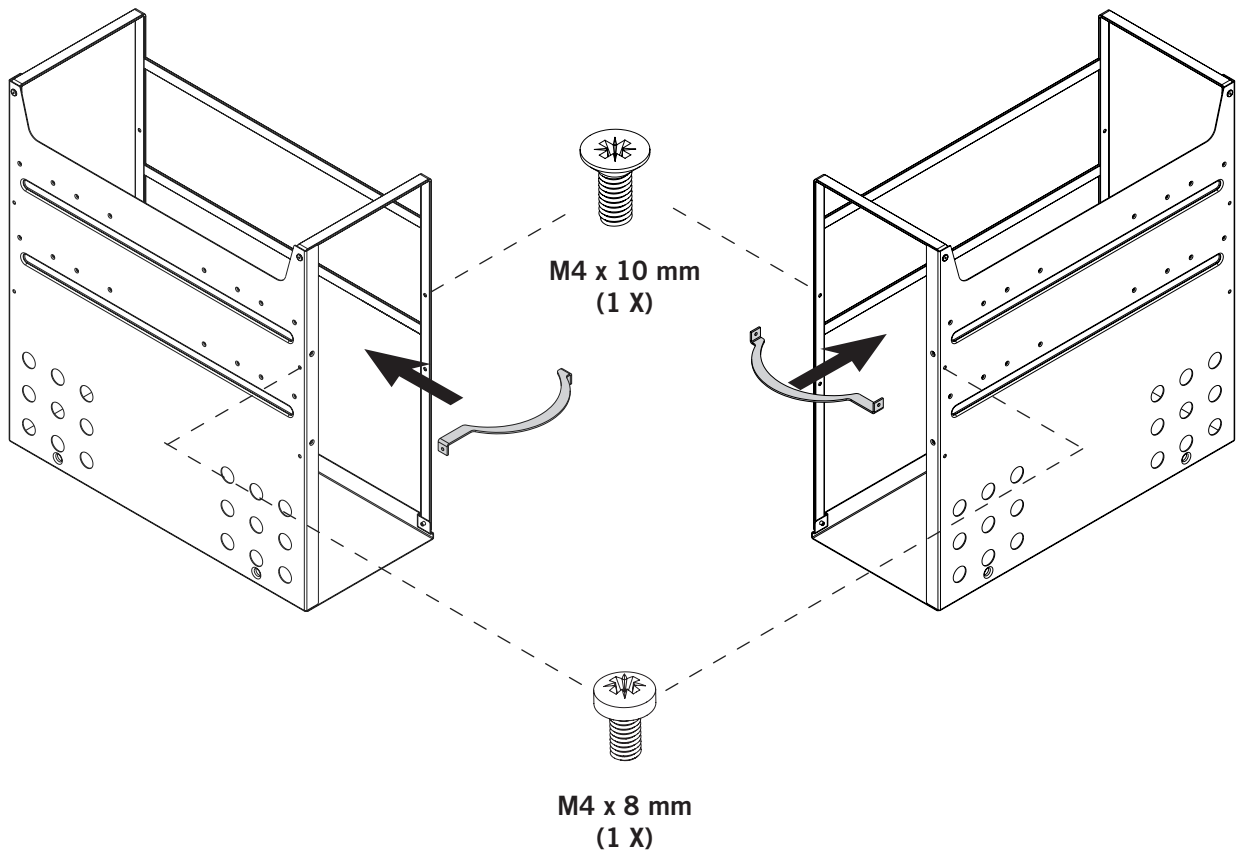
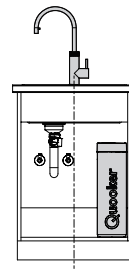
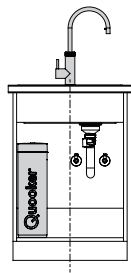
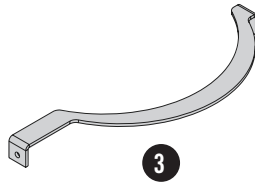

**Probeeinbau im Leerzustand (Kollisionsprüfung) durchführen. Schieben Sie dabei die vormontierte Einheit so tief in den Schrank, dass die Vorderkante der Einheit mit der Vorderkante Schrank bündig positioniert ist.**

EN Carry out trial installation in empty state (collision check). Slide the pre-assembled unit into the cabinet until the front edge of the unit is positioned flush with the front edge of the cabinet.

NL Testinbouw in lege staat (botsingscontrole) uitvoeren. Schuif daarbij de voormonteerde eenheid zo ver in de kast dat de voorkant van de eenheid vlak aansluit op de voorkant van de kast.

FR Réalisation d'un montage d'essai à l'état vide (contrôle des collisions). Enfoncez pour cela l'unité pré-montée dans le placard jusqu'à ce que le bord avant de l'unité affleure le bord arrière du placard.

DA Gennemfør testinstallation i tom tilstand (kollisionskontrol). Skub den formonterede enhed dybt nok ind i skabet til, at enhedens forkant flugter med skabets forkant.

NO Utfør en prøvemontering i tom tilstand (kollisjonstest). Skyv den forhåndsmonterte enheten inn i skapet til fremre kant på enheten er i flukt med fremre kant på skapet.

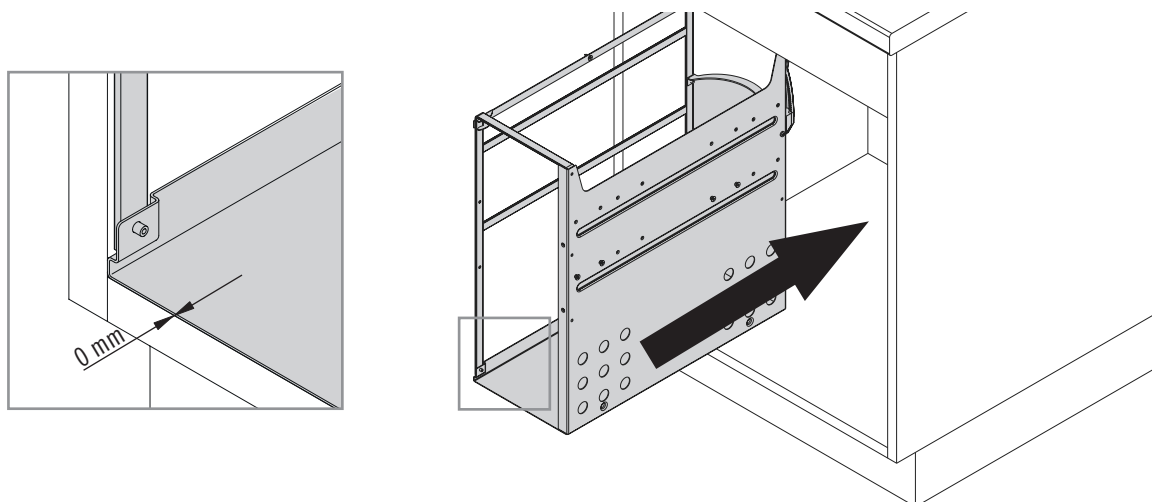

**Sollte es zur Kollision mit dem Eckventil kommen, dann kann die Kabelklemme und der Kippschutz in der Position verschoben werden.**

EN If it collides with the corner valve, the position of the cable clamp and tilt protection can be changed.

NL Als het tot een botsing met de hoekstopkraan komt, kan de positie van de kabelklem en de kantelbeveiliging worden gewijzigd.

FR Si vous observez une collision avec le robinet d'équerre, le serre-câble et le dispositif anti-basculement peuvent être déplacés.

DA Hvis der er sammenstød med hjørneventilen, kan kabelklemmen og anti-vippeanordningen flyttes på plads.

NO Dersom den kolliderer med hjørneventilen, kan kabelklammen og veltevernet flyttes.

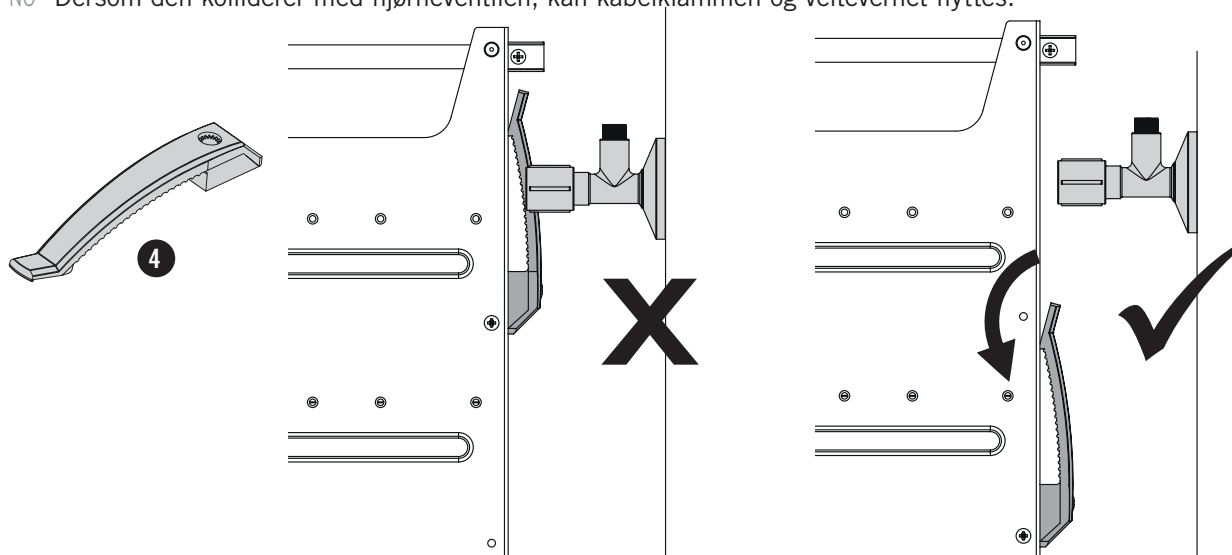

# 4



PZ 2

**Montieren Sie nun die Seitenschiene gemäß Abbildung. Achten Sie dabei auf den bündigen Einbau mit der Vorderkante.**

EN Now fit the side rail as shown in the illustration. Make sure installation is flush to the front edge.

NL Monteer nu de zijrail volgens de afbeelding. Let daarbij op de vlakke aansluiting aan de voorkant.

FR Montez à présent le rail latéral conformément à l'illustration. Faites attention au montage en saillie avec le bord avant.

DA Monter nu sideskinnen som på billedet. Vær opmærksom på, at installationen skal flugte med forkanten.

NO Deretter monterer du sideskinnen som vist på bilde. Den skal monteres i flukt med fremre kant.

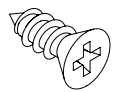
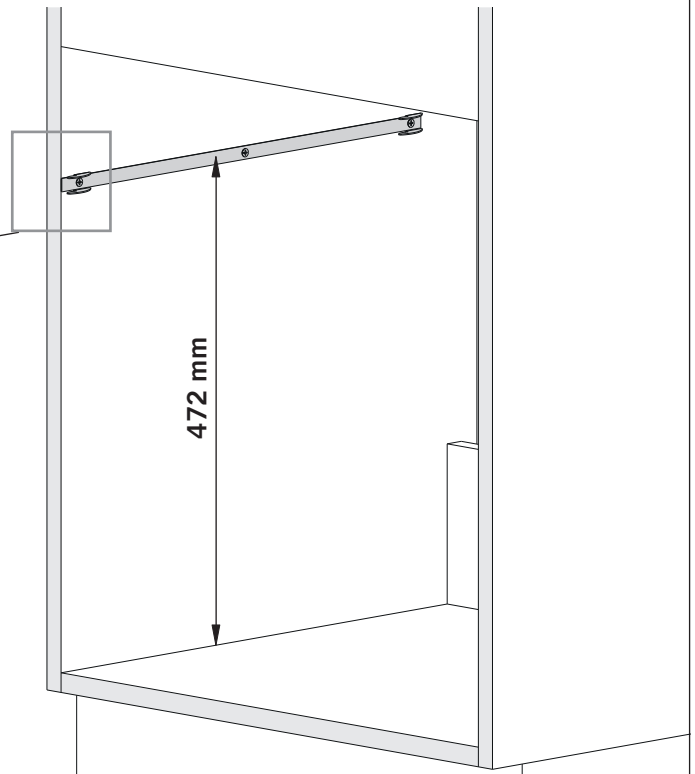
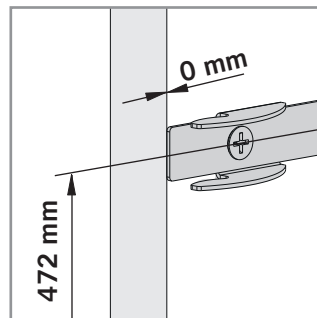
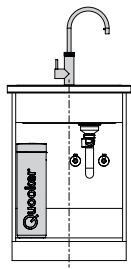

4 x 13 mm  
(3 X)

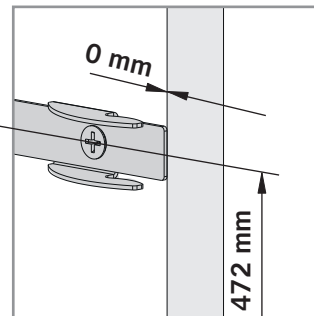
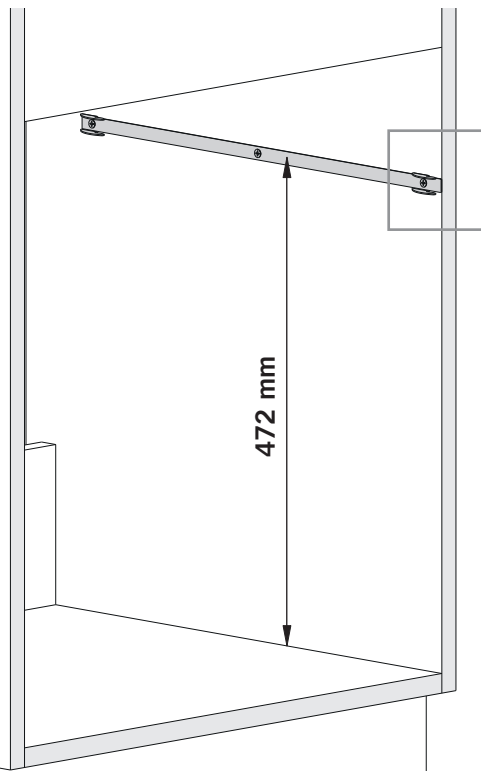
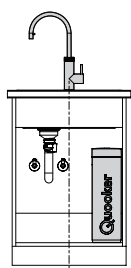



# Quooker Pro3 + CUBE

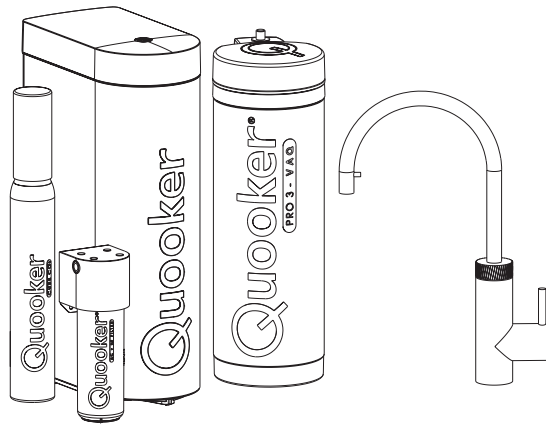

1

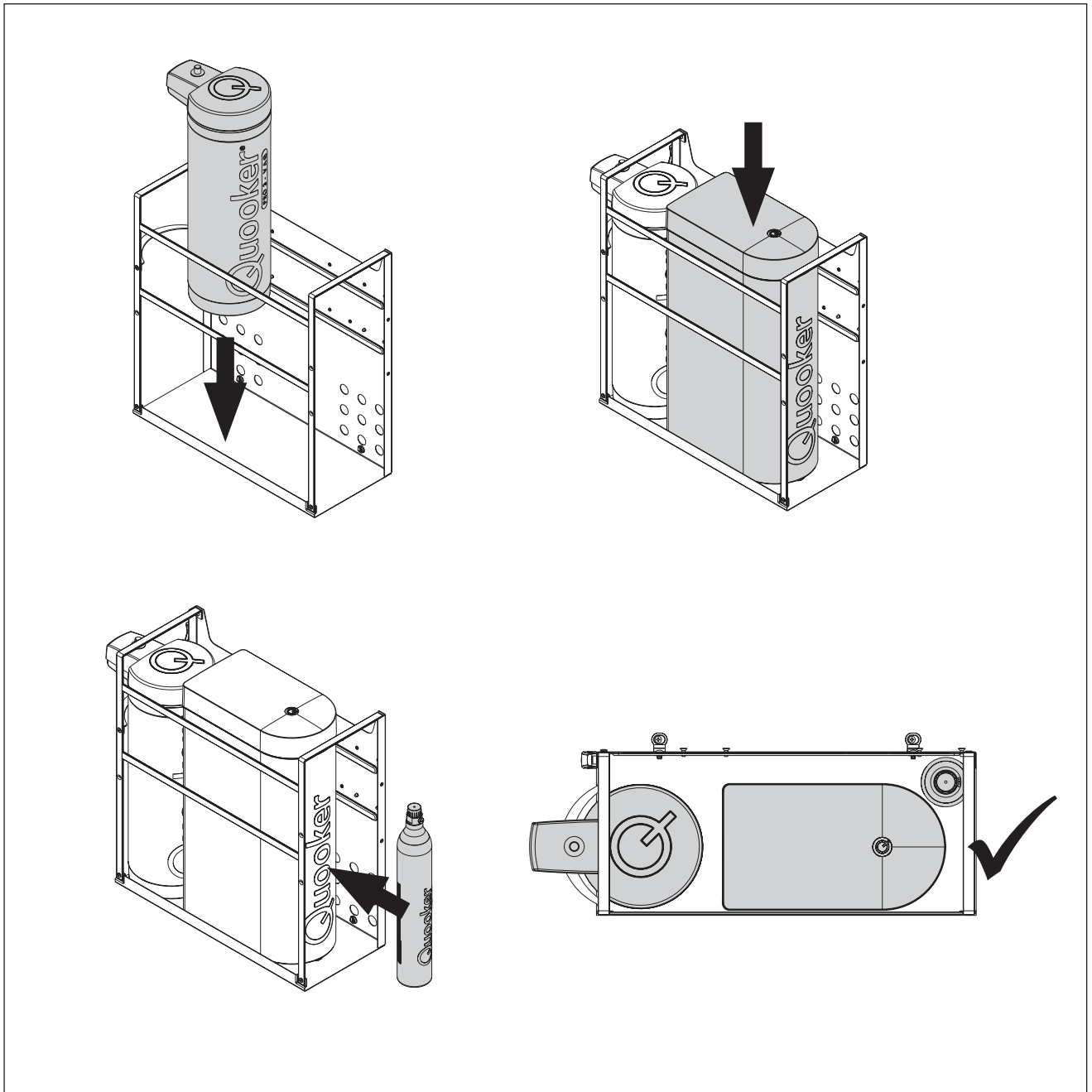



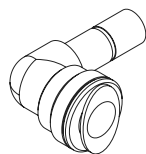

1 X

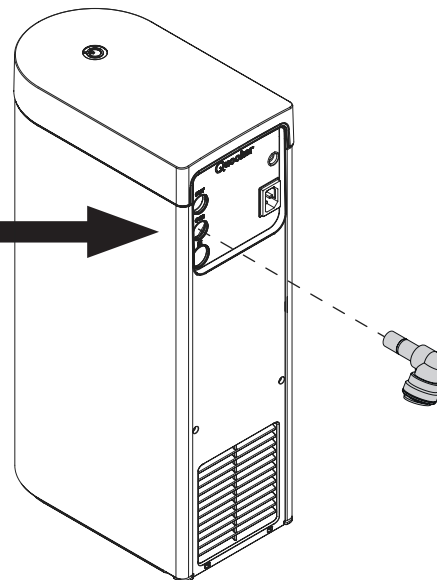

**Haben Sie ein Verlängerungsset (Quooker Mat. Nr.: VERLKALT + VERLEQ60 + VERLCUBE) mitbestellt, ist eine Verkabelung vor dem Korpus möglich. Wenn Sie einen VS ENVI® Water Filter mitbestellt haben, können Sie diesen gemäß beiliegender Montageanleitung montieren.**

**Führen Sie nun die Montage der Quooker Komponenten gemäß Quooker Montageanleitung durch.**

EN If you have ordered an extension set (Quooker mat. no.: VERLKALT + VERLEQ60 + VERLCUBE), cabling in front of the body is possible. If you have ordered a VS ENVI® Water Filter, you can install this in accordance with the enclosed installation instructions. Now carry out assembly of the Quooker components in accordance with the Quooker installation instructions.

NL Als u een verlengset (Quooker mat.-nr.: VERLKALT + VERLEQ60 + VERLCUBE) hebt meebesteld, is een bedrading vóór het corpus mogelijk. Als u een VS ENVI® Water Filter hebt meebesteld, kunt u deze volgens de meegeleverde montagehandleiding monteren. Monteer nu de Quooker-componenten volgens de Quooker-montage-handleiding.

FR Si vous avez commandé un kit de rallonge (Quooker ref. mat. : VERLKALT + VERLEQ60 + VERLCUBE), il est possible de réaliser un câblage devant le corps. Si vous avez commandé un support de filtre (VS ENVI® Water Filter), vous pouvez le monter conformément aux instructions de montage fournies. Montez à présent les composants du Quooker conformément aux instructions de montage de Quooker.

DA Har du også bestilt et forlængersæt (Quooker mat. nr.: VERLKALT + VERLEQ60 + VERLCUBE), er det muligt at føre ledningen foran selve enheden. Hvis du også har bestilt en filterholder (VS ENVI® Water Filter) kan du montere denne iht vedlagte montagevejledning. Monter nu Quooker-komponenterne iht. Quooker-monteringsvejledningen.

NO Hvis du har bestilt et forlengelsessett (Quooker mat. nr.: VERLKALT + VERLEQ60 + VERLCUBE) kan kablene monteres foran hoveddelen. Hvis du har bestilt en filterholder (VS ENVI® Water Filter) kan du montere den i samsvar med vedlagte monteringsanvisning. Nå kan du gjennomføre monteringen av Quooker-komponentene i henhold til Quooker-monteringsanvisningen.

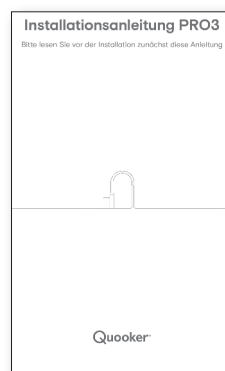
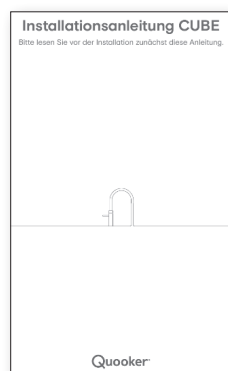



PZ 2

**Schieben Sie die ganze Einheit in den Schrank und befestigen Sie diese am Boden.**

EN Slide the entire unit into the cabinet and fasten it to the base.

NL Schuif de complete eenheid in de kast en bevestig hem aan de bodem.

FR Introduisez l'unité complète dans le placard et fixez-la sur la partie basse.

DA Skub hele enheden ind i skabet, og fastgør den til bunden.

NO Skyv hele enheten inn i skapet og fest den i gulvet.

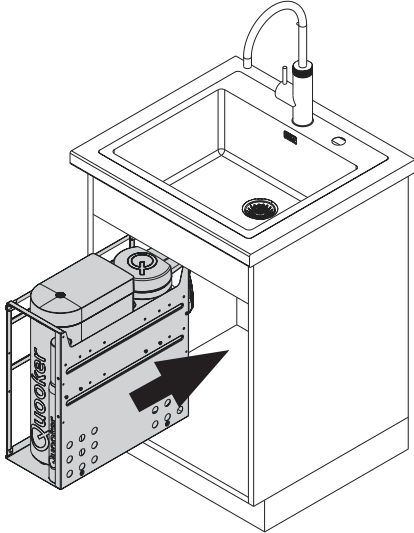

2 X

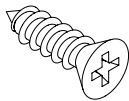

4 x 16 mm  
(2 X)

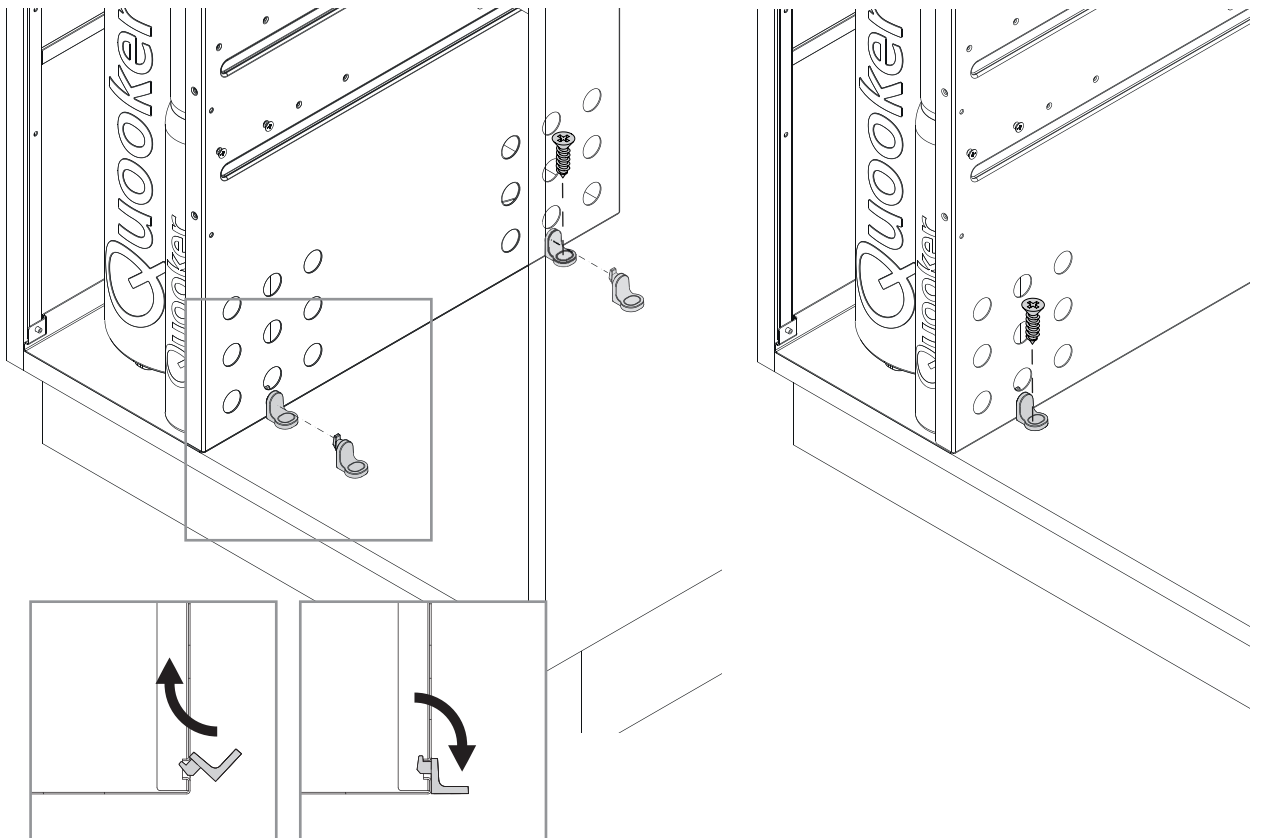



# VS ENVI® Space

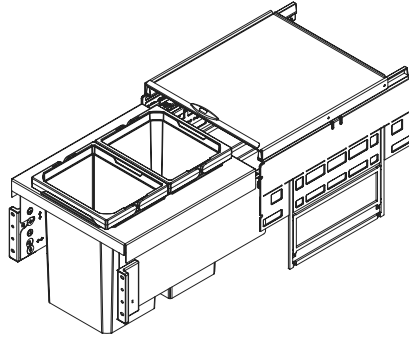

**Weitere Montage nach Montageanleitung aus Paket 1.  
Montageanleitung aus dem Paket 3 kann entsorgt werden.**

- EN Further installation according to the installation instructions in package 1.  
The installation instructions from package 3 can be discarded.
- NL Verdere montage volgens montagehandleiding uit pakket 1.  
Montagehandleiding uit pakket 3 kan worden weggegooid.
- FR Montage supplémentaire à réaliser conformément aux instructions de montage du paquet 1.  
Vous pouvez vous débarrasser des instructions de montage du paquet 3.
- DA Den videre montage følger af monteringsvejledning fra pakke 1.  
Monteringsvejledning fra pakke 3 kan bortskaffes.
- NO Den videre monteringen utføres iht. monteringsanvisningen i pakke 1.  
Monteringsanvisningen fra pakke 3 kan kastes.

