

Quote delle cerniere e calcolo delle fughe nella predisposizione di fabbrica (distanziale piastrina di premontaggio = 0 mm)

Protrusione dell'anta ad apertura piena

Battuta con sormonto

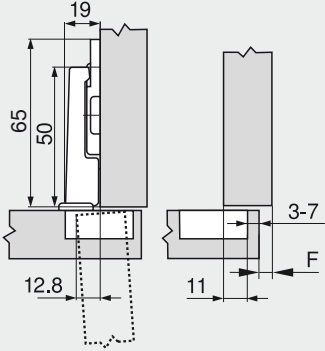
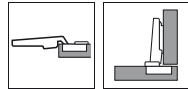

F Fuga

Distanza foratura fondello	
Battuta frontale	
	6 7 8 9 10 11 12 13 14 15 16 17 18
0	
3	
6	
9	
Piastrina di premontaggio	

Fuga minima (F) per ante con raggio (R = 1 mm) nella predisposizione di fabbrica

Distanza foratura fondello TB	Spessore del frontale FS												
	16	18	19	20	22	24	26	28	29	30	31	32	
3	0.2	0.2	0.3	0.4	0.5	0.8	1.3	2.5	3.5	4.4	5.3	6.1	
4	0.2	0.2	0.3	0.4	0.5	0.8	1.3	1.9	2.9	3.8	4.7	5.5	
5	0.2	0.2	0.3	0.4	0.5	0.8	1.2	1.7	2.4	3.2	4.0	4.9	
6	0.2	0.2	0.3	0.4	0.5	0.8	1.2	1.7	2.2	2.8	3.5	4.3	
7	0.2	0.2	0.3	0.4	0.5	0.8	1.2	1.6	2.0	2.4	3.0	3.8	
In aggiunta con regolazione laterale di + 2 mm													
	+ 0.0	+ 0.1	+ 0.1	+ 0.1	+ 0.3	+ 0.5	+ 0.4	+ 0.4	+ 0.4	+ 0.4	+ 0.3	+ 0.2	

Regolazione

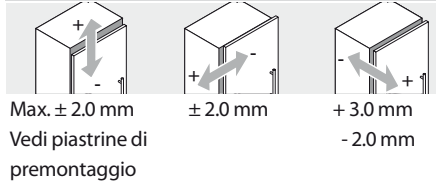

Montaggio a vite

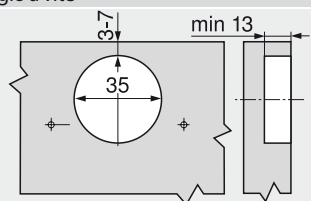

Montaggio a pressione

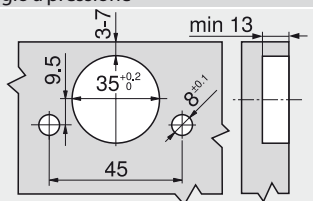

Quote fondello

