

Tvornički podešene dimenzije spojnica i izračun širine razmaka (udaljenost podloška = 0 mm)

Uškakanje vrata pri kutu punog otvaranja

Kutno pričvršćivanje vratnog krila

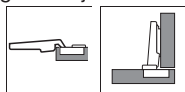

Središnje pričvršćivanje vratnog krila

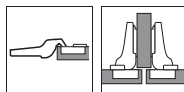

Pričvršćivanje vratnog krila unutar stranica korpusa

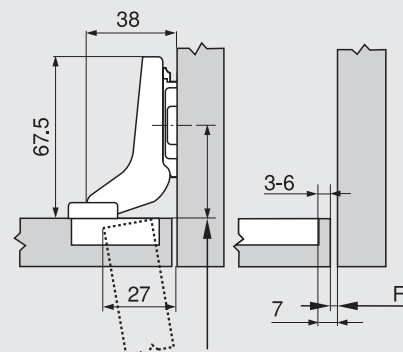
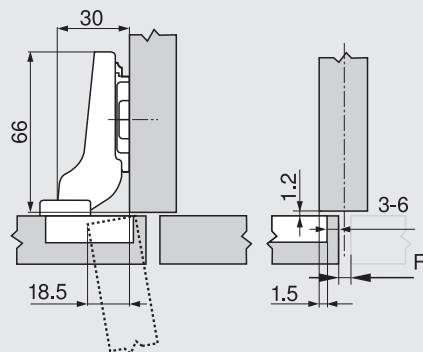
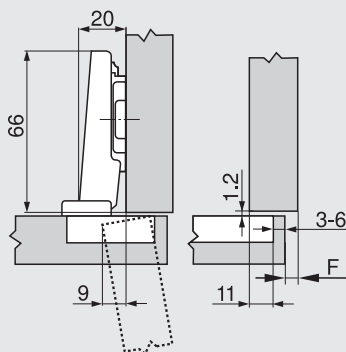
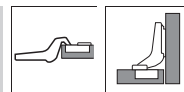

F Fuga

Položaj u kojem se podložak pričvršćuje vijcima potrebno je pomaknuti unazad za debljinu vrata + 1.5 mm

Udaljenost čašice

	Otvaranje fronte																	
	5	6	7	8	9	10	11	12	13	14	15	16	17					
0															3	4	5	6
3															3	4	5	6
6					3	4	5	6										
9	3	4	5	6														

Podložak

	Otvaranje fronte																	
	-4.5	-3.5	-2.5	-1.5	-0.5	0.5	1.5	2.5	3.5	4.5	5.5	6.5	7.5					
0															3	4	5	6
3															3	4	5	6
6															3	4	5	6
9	3	4	5	6														

Podložak

	Otvaranje fronte																
														-4	-3	-2	-1
0														3	4	5	6
3																	
6																	
9																	

Podložak

Najmanji bočni razmak (F) za fronte sa polumjerom fronte (R = 1 mm), tvorničke postavke

Udaljenost čašice TB	Debljina fronte FS											Preporučujemo vam pokus s otvaranjem	
	16	18	19	20	21	22	24	26	28	30	31		32
3	0.3	0.5	0.7	1.0	1.3	1.6	3.3						
4	0.3	0.5	0.7	1.0	1.2	1.6	3.2						
5	0.3	0.5	0.7	0.9	1.2	1.5	2.6						
6	0.3	0.5	0.7	0.9	1.1	1.4	2.4						
-													
Dodatno kod + 2 mm bočno podešavanje													
	+ 0.1	+ 0.3	+ 0.3	+ 0.4	+ 0.4	+ 0.5	+ 0.4						

Postava

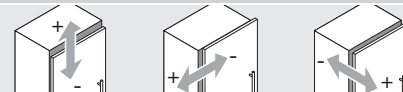

Max. ± 3.0 mm ± 2.0 mm + 3.0 mm - 1.0 mm
Pogledajte podloške

Montaža pričvršćivanjem vijcima

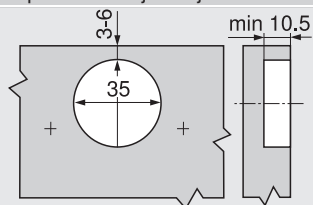

INSERTA/montaža utiskivanjem

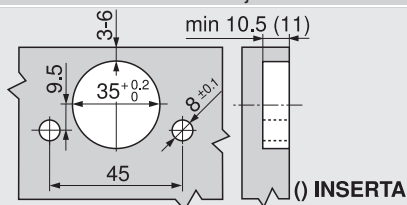

Dimenzije čašice

