

Vorbereitung / Bohrungen

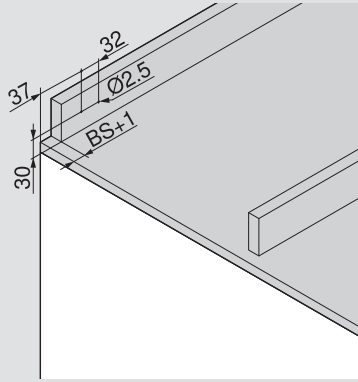

Bohrung für Montageplatte

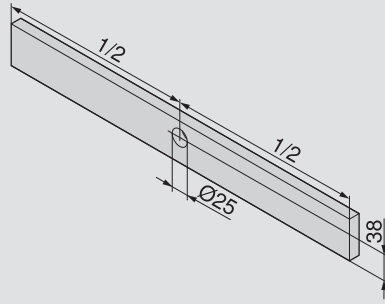

Bohrung Frontblende

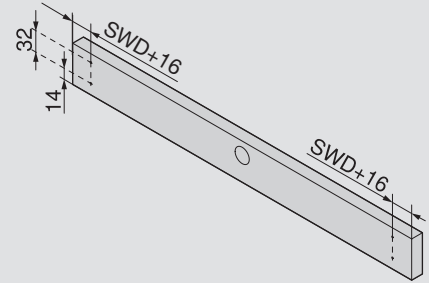

Planung Antriebseinheit

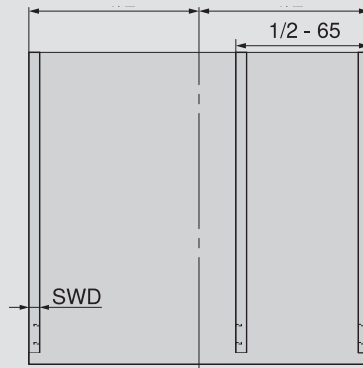
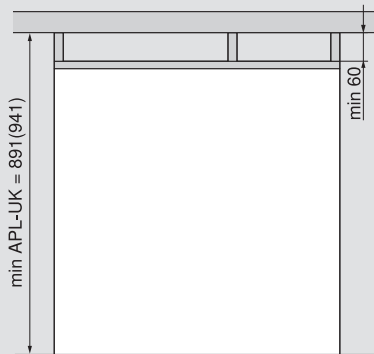

Zugriff bei Arbeitsplatten-Überstand

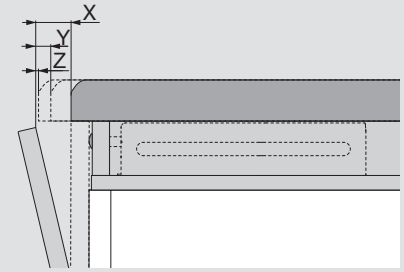

X	30 mm	APÜ	0 mm
Y	10 mm	APÜ	20 mm
Z	0 mm	APÜ	30 mm

NH	Nischenhöhe
BS	Blendenspalt
SWD	Seitenwanddicke

APL-UK	Arbeitsplatten-Unterkante
APÜ	Arbeitsplatten-Überstand