

Planiranje

Tvornički podešene dimenzije spojnica i izračun širine razmaka (udaljenost podloška = 0 mm)

Uskakanje vrata pri kutu punog otvaranja

Kutno pričvršćivanje vratnog krila

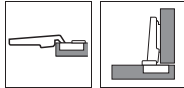

Središnje pričvršćivanje krila

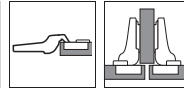

Pričvršćivanje vratnog krila unutar stranica korpusa

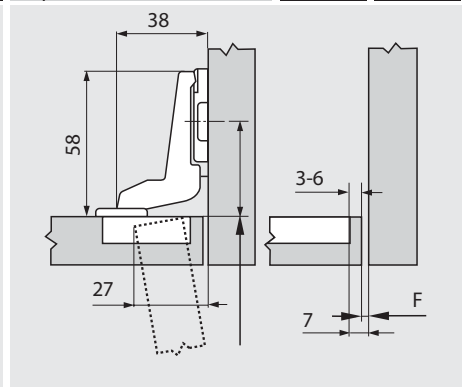
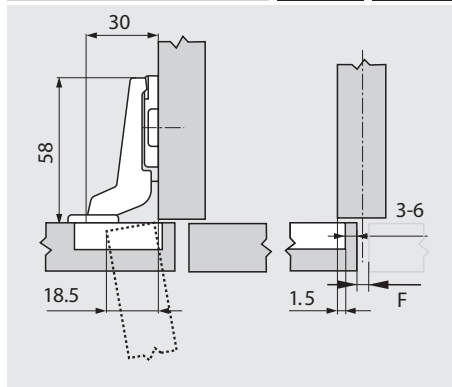
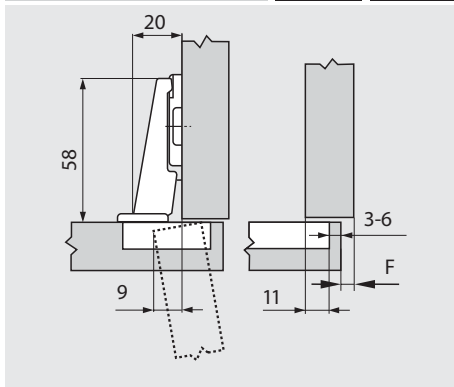
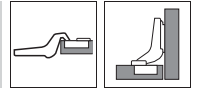

F Fuga

Položaj pričvršćivanja podloška potrebno je pomaknuti unazad za debljinu vrata

Udaljenost čašice

	Otvoranje fronte																
	5	6	7	8	9	10	11	12	13	14	15	16	17				
0														3	4	5	6
3							3	4	5	6							
9	3	4	5	6													
-																	

Podložak

	Otvoranje fronte																
	-4.5	-3.5	-2.5	-1.5	-0.5	0.5	1.5	2.5	3.5	4.5	5.5	6.5	7.5				
0														3	4	5	6
3										3	4	5	6				
9	3	4	5	6													
-																	

Podložak

	Otvoranje fronte																				
																		-4	-3	-2	-1
0																		3	4	5	6
3																					
9																					
-																					

Podložak

Najmanji bočni razmak (F) za fronte s polumjerom fronte (R = 1 mm), tvorničke postavke

Udaljenost čašice TB	Debljina fronte FS													
	16	18	19	20	21	22	24	26	28	30	31	32		
3	0.3	0.5	0.7	1.0	1.3	1.6	3.3	Preporučujemo vam pokus s otvaranjem						
4	0.3	0.5	0.7	1.0	1.2	1.6	3.2							
5	0.3	0.5	0.7	0.9	1.2	1.5	2.6							
6	0.3	0.5	0.7	0.9	1.1	1.4	2.4							
-														
Dodatno kod + 2 mm bočno podešavanje														
	+0.1	+0.3	+0.3	+0.4	+0.4	+0.5	+0.4							

Postava

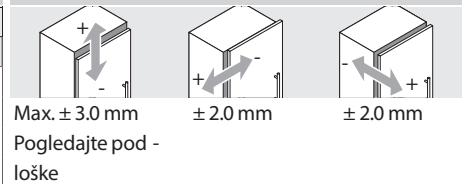

Montaža pričvršćivanjem vijcima

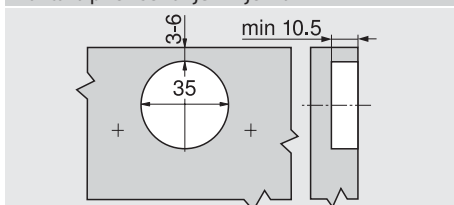

Montaža utiskivanjem

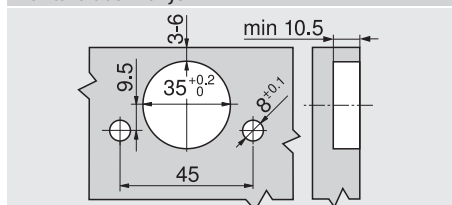

Dimenzije čašice

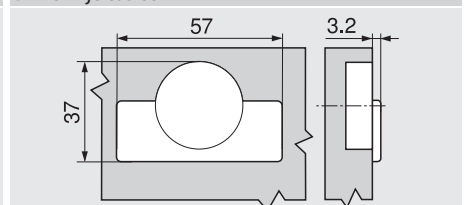

M MODUL