

Foratura per piastra di montaggio

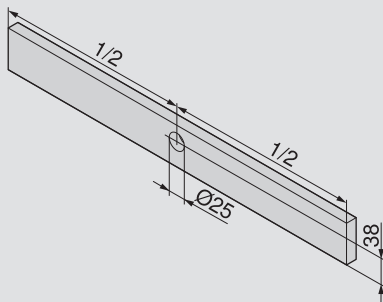

Foratura frontale di copertura

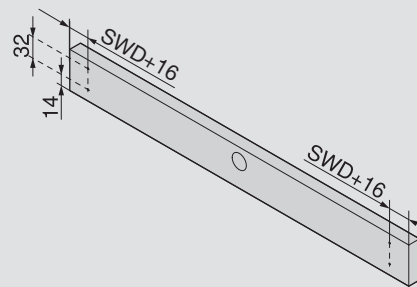

Accesso in caso di sormonto del piano di lavoro

Progettazione unità motrice

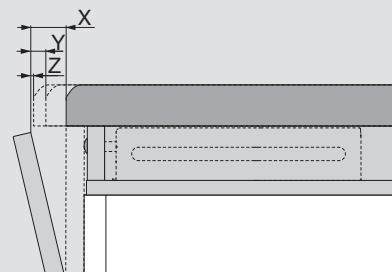
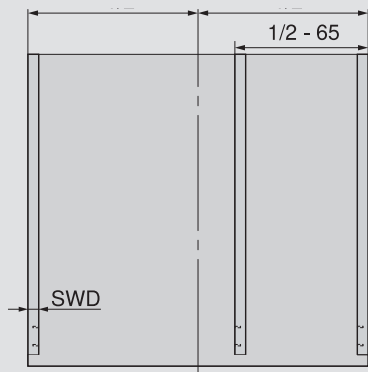
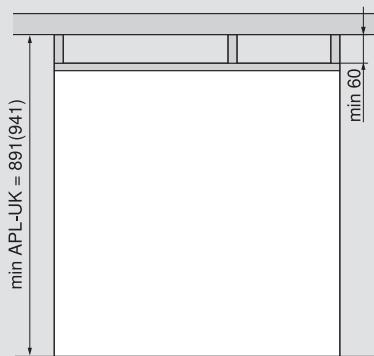

X	30 mm	APÜ	0 mm
Y	10 mm	APÜ	20 mm
Z	0 mm	APÜ	30 mm

NH Altezza nicchia

BS Spessore frontale di copertura

SWD Spessore pareti laterali

APL-UK Bordo inferiore piano di lavoro

APÜ Sormonto piano di lavoro