

Priestorové požiadavky

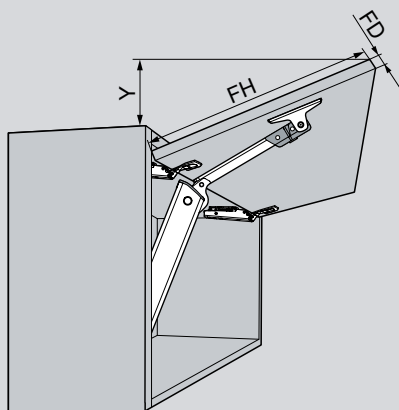

$$Y = (FH - a) \times 0.3$$

| | | | | |
|---------|----|----|----|----|
| FD (mm) | 16 | 19 | 22 | 24 |
| a (mm) | 45 | 34 | 23 | 15 |

FD Hrúbka čela

FH Výška čela

Priestorové požiadavky – vencové lišty a rampy

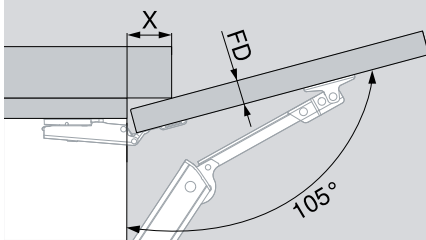

| | | | | |
|---------|----|----|----|----|
| FD (mm) | 16 | 19 | 22 | 24 |
| X (mm) | 45 | 34 | 23 | 15 |

FD Hrúbka čela

Minimálna medzera

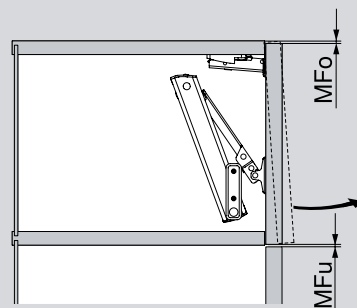

MFu Minimálna medzera dolu (1.5 mm)

MFo Minimálna medzera hore, v závislosti od použitého závesu – pozri katalóg Blum

Minimálna medzera (F) pre čelo s polomerom hrany (R = 1 mm) pri nastavení z výroby pre CLIP top BLUMOTION 110° / CLIP top 110°

| | | Hrúbka čela FD | | | | | | | | | | | Odporúčame skúšku naloženia |
|--|----|---------------------------------------|------|------|------|------|------|------|------|------|------|------|--------------------------------|
| | | 16 | 18 | 19 | 20 | 21 | 22 | 23 | 24 | 25 | 26 | 28 | |
| | TB | 3 | 0.5 | 0.8 | 1.0 | 1.2 | 1.5 | 1.8 | 2.2 | 2.7 | 3.5 | 4.3 | |
| | | 4 | 0.5 | 0.8 | 1.0 | 1.2 | 1.4 | 1.7 | 2.0 | 2.5 | 3.1 | 3.8 | |
| | | 5 | 0.5 | 0.8 | 0.9 | 1.2 | 1.4 | 1.7 | 2.0 | 2.4 | 2.9 | 3.4 | |
| | | 6 | 0.5 | 0.8 | 0.9 | 1.2 | 1.3 | 1.6 | 1.9 | 2.3 | 2.7 | 3.2 | |
| | | 7 | 0.5 | 0.8 | 0.9 | 1.1 | 1.3 | 1.6 | 1.9 | 2.2 | 2.6 | 3.0 | |
| | | Navyše pri nastavení do strany + 2 mm | | | | | | | | | | | |
| | | +0.2 | +0.4 | +0.4 | +0.5 | +0.5 | +0.5 | +0.5 | +0.5 | +0.5 | +0.5 | +0.5 | |

CLIP top BLUMOTION 110° / CLIP top 110°

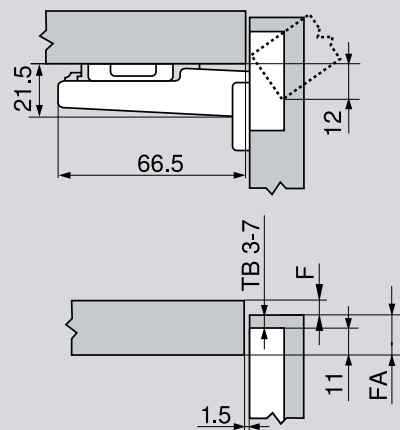

F Medzera

FA Presah čela

TB Odstup misky

CLIP top BLUMOTION 110°/CLIP top 110°

| | | Presah čela FA | | | | | | | | | | | | | | | |
|--|----|-------------------|---|---|---|---|----|----|----|----|----|----|----|----|----|--|--|
| | | 5 | 6 | 7 | 8 | 9 | 10 | 11 | 12 | 13 | 14 | 15 | 16 | 17 | 18 | | |
| | TB | 0 | | | | | | | | | 3 | 4 | 5 | 6 | 7 | | |
| | | 3 | | | | | | 3 | 4 | 5 | 6 | 7 | | | | | |
| | | 6 | | | 3 | 4 | 5 | 6 | 7 | | | | | | | | |
| | | 9 | 3 | 4 | 5 | 6 | 7 | | | | | | | | | | |
| | | Montážna podložka | | | | | | | | | | | | | | | |

TB Odstup misky