

Príprava / Vŕtania

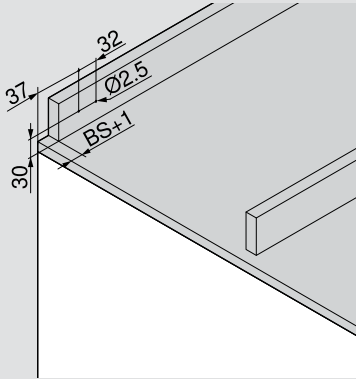

Vŕtanie pre montážnu podložku

BS 16-19 mm

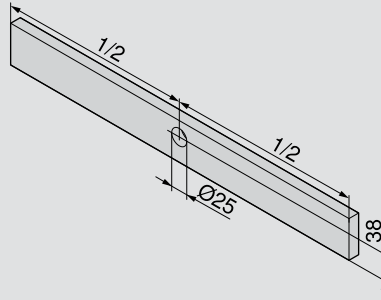

Vŕtanie čelného panelu

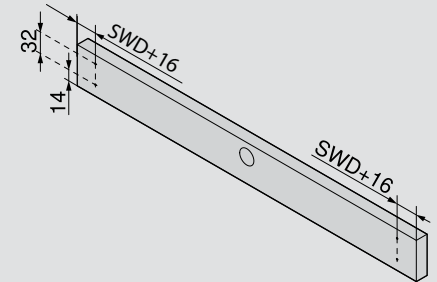

Projektovanie servojednotky

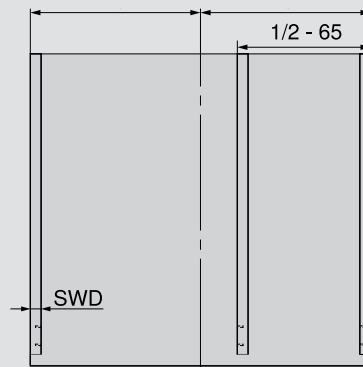
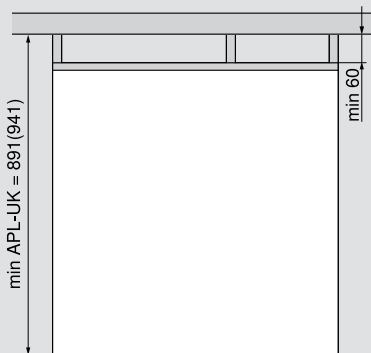

Prístup pri presahu pracovných dosiek

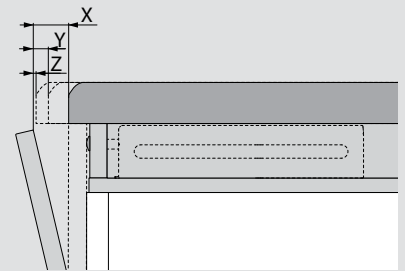

X	30 mm	APÜ	0 mm
Y	10 mm	APÜ	20 mm
Z	0 mm	APÜ	30 mm

NH	Výška niky
BS	Hrúbka panelu
SWD	Hrúbky boku

APL-UK	Spodná hrana pracovnej dosky
APÜ	Presah pracovnej dosky